

HardROC Rock Drilling Tools

— Product Catalogue [TH/DTH/Rotary]



Drill For Quality Hole



I CONTENTS

INTEGRAL AND TAPER ROD	06
• Integral Drill Rods	07
• Tapered Rods	08
• Tapered Bits	09
TH THREAD PRODUCTS	11
• R25	12
• R28	15
• R32	17
• R/T38	21
• T45	26
• T51	29
• GT60	33
• ST58	34
• ST68	35
SHANK ADAPTER	36
DTH HAMMER	38
• DTH4 Inch	39
• DTH5 Inch	40
• DTH6 Inch	41
• DTH8 Inch	42
DTH BIT	43
• DTH Bit	44
• DTH Bit Design	45
DTH PIPE	46
ROTARY TOOLS	48
• Rotary Bit	49
• Rotary Drill String	50

GUIDE TO PRODUCT CODES

Product codes are a valuable tool to describe and identify the product. In the code we have described the product features with an alpha-numerical system. With the attached key you will be able to find the product you are looking for or an alternative product.

Integrals

Example: 5H22-341810-800-40-2 = H22 Integral rod, Carbide 34x18x10, Integrals rod length 800, Steel grade Z708, Carbide grade 4A

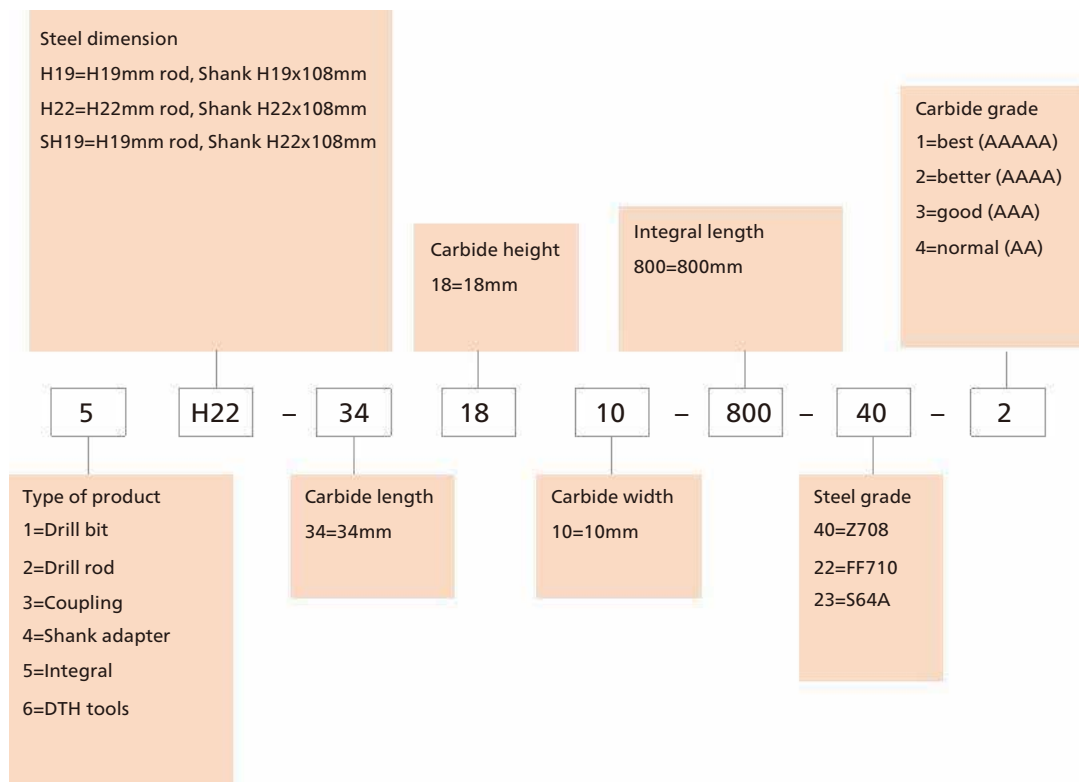

GUIDE TO PRODUCT CODES

Drill Bit

Example 1: 1111-42723-13 / 9-40-13 = Horseshoe bit, Diameter 42mm, Tapered 7° degree, Carbide height 13.5mm, width 9.2mm, 40Cr steel, Carbide bottom is flat, Carbide grade is good.

Example 2: 1432-76T45-511 / 81245-41 = New drop center button bit, Diameter 76mm, Thread T45, Front button 5x11mm, Gauge button 8x12mm, Body steel 45CrNiMoV, best Hemispherical carbide

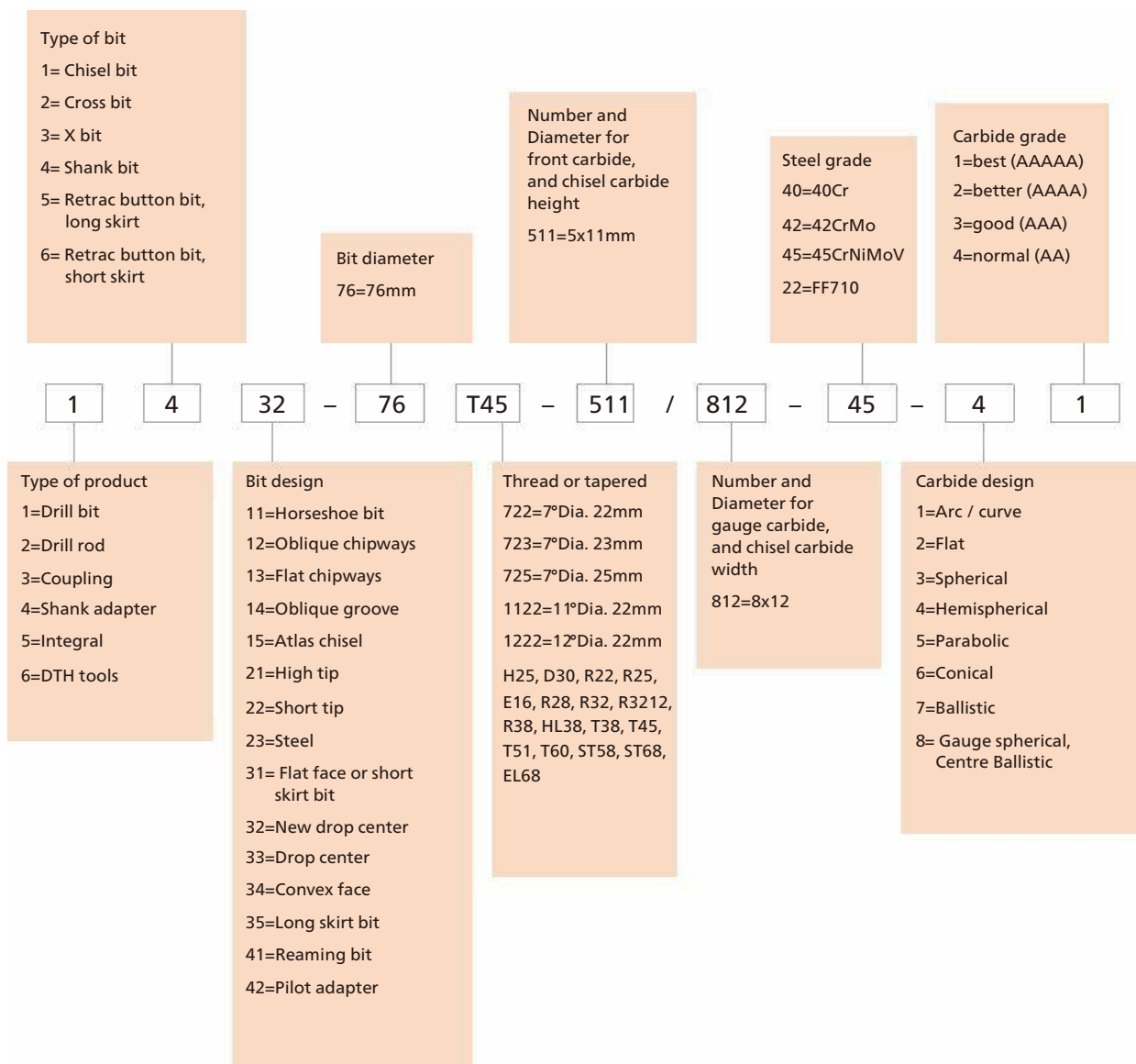

GUIDE TO PRODUCT CODES

Drill Rod

Example 1: 21H22-7 / 108-2800-40=Hex. 22 tapered rod, Tapered 7°, Shank length 108mm, Steel grade 2708, Rod length 2.8m

Example 2: 22H28-R28 / R324310-23A=Hex. 28 drifting rod, Thread at bit end R28, Thread at shank end R32, Steel grade S64A, Rod length 4.31m



GUIDE TO PRODUCT CODES

Coupling, Crossover & Bit adapters

Example 1: 33-R32/R3855-180-23A=Adapter coupling, 1st thread is R32, 2nd thread is R38, Coupling diameter is 55mm, Coupling length is 180mm, Steel grade is S64A.

Example 2: 30-R32-44-155=Non-bridge coupling, 1st thread is R32, 2nd thread is R32, Coupling diameter is 44mm, Coupling length is 155mm, Steel grade is S64A.

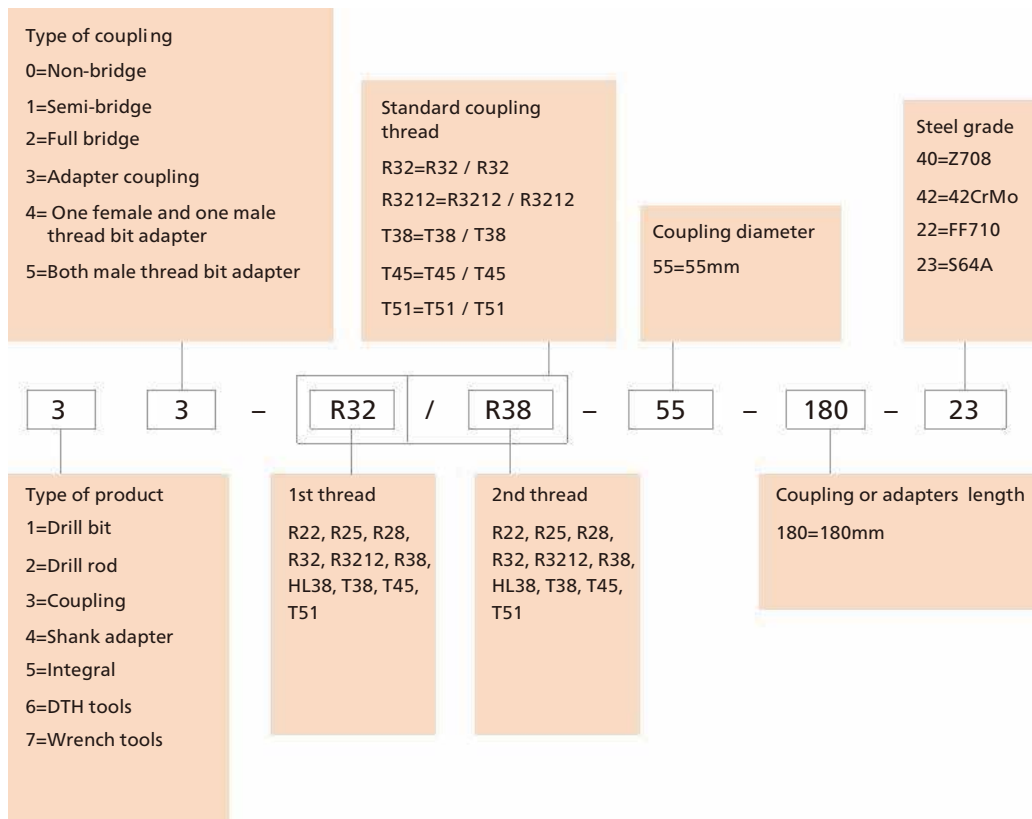



Integral And Taper Rod

Integral | Tapered | Tapered Bit

INTEGRAL DRILL RODS

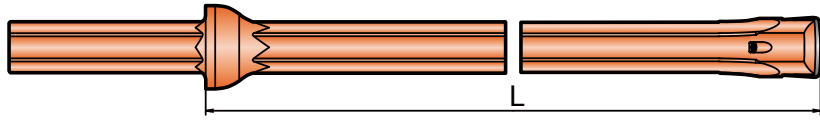

Series	Product No.	Product Code	Length (mm)	Dia (mm)	Weight (kg)
HID 1	HI10001000	5H22-351810-600-40-2	600	35	2.20
	HI10001001	5H22-341810-1200-40-2	1200	34	4.00
	HI10001002	5H22-331810-1800-40-2	1800	33	5.80
	HI10001003	5H22-321808-2400-40-2	2400	32	7.70
HID 2	HI10001004	5H22-411810-600-40-2	600	41	2.20
	HI10001005	5H22-401810-1200-40-2	1200	40	4.00
	HI10001006	5H22-391810-1800-40-2	1800	39	5.80
	HI10001007	5H22-381810-2400-40-2	2400	38	7.70
	HI10001008	5H22-401810-400-40-2	400	40	1.60
	HI10001009	5H22-411810-400-40-2	400	41	1.60
	HI10001010	5H22-341810-600-40-2	600	34	2.20
	HI10001011	5H22-331810-1200-40-2	1200	33	4.00
	HI10001012	5H22-391810-1200-40-2	1200	39	4.00
	HI10001013	5H22-321810-1600-40-2	1600	32	5.20
	HI10001014	5H22-341810-1600-40-2	1600	34	5.20
	HI10001015	5H22-401810-1600-40-2	1600	40	5.20
	HI10001016	5H22-341810-1800-40-2	1800	34	5.80
	HI10001017	5H22-361810-1800-40-2	1800	36	5.80
	HI10001018	5H22-381810-1800-40-2	1800	38	5.80
	HI10001019	5H22-401810-1800-40-2	1800	40	5.80
	HI10001020	5H22-381810-2000-40-2	2000	38	6.50
	HI10001021	5H22-341810-2400-40-2	2400	34	7.70
	HI10001022	5H22-401810-2400-40-2	2400	40	7.70
	HI10001023	5H22-381810-3200-40-2	3200	38	10.10
HI10001024	5H22-381810-4000-40-2	4000	38	12.60	

Integral and Taper Rod

TH Thread Products

Shank Adapter

DTH Hammer

DTH Bit

DTH Pipe

Rotary Tools

TAPER RODS

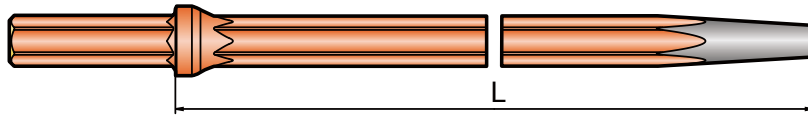

Taper	Product No.	Product Code	Total Length(mm)	L (excluding Shank)	Weight (kg)
12°	HT10001000	21H22-12/108-718-40	718	610	2.20
	HT10001001	21H22-12/108-800-40	800	692	2.45
	HT10001002	21H22-12/108-908-40	908	800	2.78
	HT10001003	21H22-12/108-1000-40	1000	892	3.06
	HT10001004	21H22-12/108-1025-40	1025	917	3.14
	HT10001005	21H22-12/108-1200-40	1200	1092	3.67
	HT10001006	21H22-12/108-1220-40	1220	1112	3.73
	HT10001007	21H22-12/108-1320-40	1320	1212	4.04
	HT10001008	21H22-12/108-1328-40	1328	1220	4.06
	HT10001009	21H22-12/108-1635-40	1635	1527	5.00
	HT10001010	21H22-12/108-1800-40	1800	1692	5.51
	HT10001011	21H22-12/108-1908-40	1908	1800	5.84
	HT10001012	21H22-12/108-1938-40	1938	1830	5.93
	HT10001013	21H22-12/108-2000-40	2000	1892	6.12
	HT10001014	21H22-12/108-2108-40	2108	2000	6.45
	HT10001015	21H22-12/108-2508-40	2508	2400	7.67
	HT10001016	21H22-12/108-2548-40	2548	2440	7.80
	HT10001017	21H22-12/108-3158-40	3158	3050	9.66
	HT10001018	21H22-12/108-3308-40	3308	3200	10.12
	HT10001019	21H22-12/108-4108-40	4108	4000	12.57
	HT10001020	21H22-12/108-4508-40	4508	4400	13.79
	HT10001021	21H22-12/108-4908-40	4908	4800	15.02
	HT10001022	21H22-12/108-5708-40	5708	5600	17.47
	HT10001023	21H22-12/108-6508-40	6508	6400	19.91
	HT10001024	21H22-12/108-7308-40	7308	7200	22.36
	HT10001025	21H22-12/108-8108-40	8108	8000	24.81
HT10001026	21H22-12/108-8908-40	8908	8800	27.26	
7°	HT10001027	21H22-7/108-708-40	708	600	2.17
	HT10001028	21H22-7/108-908-40	908	800	2.78
	HT10001029	21H22-7/108-1108-40	1108	1000	3.39
	HT10001030	21H22-7/108-1308-40	1308	1200	4.00
	HT10001031	21H22-7/108-1608-40	1608	1500	4.92
	HT10001032	21H22-7/108-1908-40	1908	1800	5.84
	HT10001033	21H22-7/108-2400-40	2400	2292	7.34
	HT10001034	21H22-7/108-2500-40	2500	2392	7.65
	HT10001035	21H22-7/108-2600-40	2600	2492	7.96
	HT10001036	21H22-7/108-3000-40	3000	2892	9.18
	HT10001037	21H22-7/108-3100-40	3100	2992	9.49
	HT10001038	21H22-7/108-3200-40	3200	3092	9.79
	HT10001039	21H22-7/108-4000-40	4000	3892	12.24
	HT10001040	21H22-7/108-4100-40	4100	3992	12.55
	HT10001041	21H22-7/108-4500-40	4500	4392	13.77
	HT10001042	21H22-7/108-5000-40	5000	4892	15.30
	HT10001043	21H22-7/108-5500-40	5500	5392	16.83
	HT10001044	21H22-7/108-6000-40	6000	5892	18.36
	HT10001045	21H22-7/108-6500-40	6500	6392	19.89
	HT10001046	21H22-7/108-7000-40	7000	6892	21.42
HT10001047	21H22-7/108-8000-40	8000	7892	24.48	
HT10001048	21H22-7/108-9000-40	9000	8892	27.54	

Integral and Taper Rod

TH Thread Products

Shank Adapter

DTH Hammer

DTH Bit

DTH Pipe

Rotary Tools

TAPER BITS

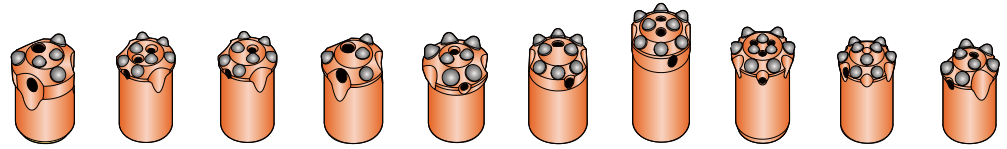

Dia	Product No.	Product Code	Face Type	Buttons		Flushing		Angle	Weight (kg)
				Gauge No. X Size (mm)	Center No. X Size (mm)	Gauge No. X Size (mm)	Center No. X Size (mm)	Gauge Buttons	

Short Skirt, Ballistic Buttons, 12°

28	HT10002001	R1431-281220-17/47-45-53	Flat	4 x 7	1 x 7	2x5	1x5	35°	0.20
30	HT10002002	1431-301222-17/47-45-51	Flat	4 x 7	1 x 7	2x5	1x5	35°	0.22
33	HT10002003	R1431-331222-27/58-42-53	Flat	5 x 8	2 x 7	1x5	1x4	35°	0.25
34	HT10002004	1431-341222-27/47-45-51	Flat	4 x 7	2 x 7	1x5	2x5	35°	0.29
34	HT10002005	R1431-341222-27/57-45-53	Flat	5 x 7	2 x 7	1x4	1x4	35°	0.29
34	HT10002006	R1434-341222-27/67-42-53	Convex	6 x 7	2 x 7	1x4	2x4	15°,45°	0.29
35	HT10002007	R1431-351222-27/58-45-51	Flat	5 x 8	2 x 7	1x5	1x5	35°	0.33
38	HT10002008	1431-381222-27/58-42-53	Flat	5 x 8	2 x 7	1x5	1x5	35°	0.40

Short Skirt, Ballistic Buttons, 7°

28	HT10002008	R1431-28719-17/37-45-51	Flat	3 x 7	1 x 7	1x5	1x3.5	30°	0.18
30	HT10002009	R1431-30722-27/47-42-53	Flat	4 x 7	2 x 7	1x5	1x4	30°	0.21
32	HT10002010	R1431-32722-17/38-42-53	Flat	3 x 8	1 x 7	1x5	1x4	30°	0.24
32	HT10002011	1431-32722-18/38-40-53	Flat	3 x 8	1 x 8	1x5	1x4	30°	0.24
32	HT10002012	R1431-32722-27/57-45-51	Flat	5 x 7	2 x 7	1x3.8	1x3.5	35°	0.24
34	HT10002013	1431-34722-17/38-42-53	Flat	3 x 8	1 x 7	1x5	1x4	30°	0.29
34	HT10002014	R1431-34722-27/47-42-53	Flat	4 x 7	2 x 7	1x5	1x5	35°	0.29
34	HT10002015	R1431-34722-27/57-45-51	Flat	5 x 7	2 x 7	1x4	1x4	35°	0.29
34	HT10002016	R1431-34722-27/67-42-53	Flat	6 x 7	2 x 7		2x4.5	35°	0.29
35	HT10002017	R1431-35722-27/58-45-51	Flat	5 x 8	2 x 7	1x5	1x5	35°	0.33
36	HT10002018	R1431-36722-27/58-45-51	Flat	5 x 8	2 x 7	1x5	1x5	35°	0.37
36	HT10002019	R1431-36722-18/39-42-53	Flat	3 x 9	1 x 8	1x5	1x5	30°	0.37
38	HT10002020	1431-38723-18/38-42-53	Flat	3 x 8	1 x 8	1x5	1x5	30°	0.38
38	HT10002021	R1431-38722-27/58-42-53	Flat	5 x 8	2 x 7	1x5	1x5	35°	0.38
38	HT10002022	R1431-38722-27/68-42-53	Flat	6 x 8	2 x 7		2x5	35°	0.38
38	HT10002023	R1431-38723-19/39-42-53	Flat	3 x 9	1 x 9	1x5	1x5	30°	0.38
40	HT10002024	1431-40723-18/39-42-53	Flat	3 x 9	1 x 8	1x6	1x6	30°	0.40
40	HT10002025	1431-40723-18/39-42-53	Flat	3 x 9	1 x 8	1x6	1x6	30°	0.40
40	HT10002026	R1431-40723-19/39-35-53	Flat	3 x 9	1 x 9	2x5	1x6.5	35°	0.40
40	HT10002027	R1431-40723-19/39-42-53	Flat	3 x 9	1 x 9	1x6	1x6	35°	0.40
40	HT10002028	R1431-40723-19/39-42-53	Flat	3 x 9	1 x 9	1x6	1x6	35°	0.40
40	HT10002029	R1431-40723-19/39-45-51	Flat	3 x 9	1 x 9	1x6	1x6	35°	0.40
40	HT10002030	R1431-40725-28/59-45-41	Flat	5 x 9	2 x 8	1x6	1x5	35°	0.40
40	HT10002031	R1431-40723.3-19/39-45-53	Flat	3 x 9	1 x 9	1x6	1x6	35°	0.40
40	HT10002032	R1431-40723-19/39-42-53X	Flat	3 x 9	1 x 9	1x5	1x5	35°	0.40
40	HT10002033	R1431-40723-28/59-42-53	Flat	5 x 9	2 x 8	1x5	1x5	35°	0.40

Integral and Taper Rod

TH Thread Products

Shank Adapter

DTH Hammer

DTH Bit

DTH Pipe

Rotary Tools

TAPER BITS

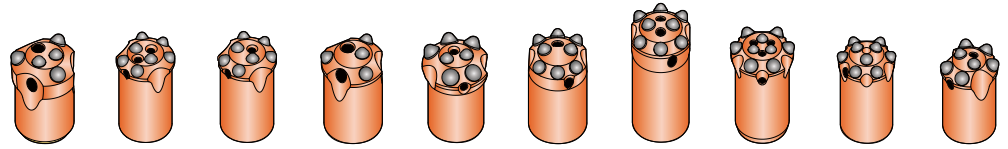

Dia (mm)	Product No.	Product Code	Face Type	Buttons		Flushing		Angle	Weight (kg)
				Guage No. X Size (mm)	Center No. X Size (mm)	Guage No. X Size (mm)	Center No. X Size (mm)	Guage Buttons	

Short Skirt, Ballistic Buttons, 7°

40	HT10002034	R1431-40723-29/39-42-53	Flat	3 x 9	2 x 9	1x5.5	1x5.5	35°	0.40
40	HT10002035	R1431-40725-28/59-42-53	Flat	5 x 9	2 x 8	1x6	1x5	35°	0.40
41	HT10002036	R1435-41725-28/59-45-51	Flat	5 x 9	2 x 8	1x6	1x5	35°	0.42
42	HT10002037	1431-42722-18/39-42-53	Flat	3 x 9	1 x 8	1x5.5	1x5.5	30°	0.43
42	HT10002038	R1431-42722-28/59-45-31	Flat	5 x 9	2 x 8	1x6	1x5	35°	0.43
42	HT10002039	1431-42723-18/39-42-53	Flat	3 x 9	1 x 8	1x5.5	1x5.5	30°	0.43
42	HT10002040	R1431-42723-19/39-35-53	Flat	3 x 9	1 x 9	1x5.5	1x5.5	35°	0.43
42	HT10002041	R1431-42723-19/39-45-51	Flat	3 x 9	1 x 9	1x5.5	1x5.5	35°	0.43
42	HT10002042	R1431-42723-29/39-42-53	Flat	3 x 9	2 x 9	1x5.5	1x5.5	35°	0.43
42	HT10002043	R1431-42722-28/59-45-51	Flat	5 x 9	2 x 8	1x6	1x5	35°	0.43
42	HT10002044	R1431-42723.3-19/39-45-53	Flat	3 x 9	1 x 9	1x6	1x6	35°	0.43
42	HT10002045	R1431-42725-28/59-42-53	Flat	5 x 9	2 x 8	1x6	1x6	35°	0.43
43	HT10002046	1431-43723-17/38-42-53	Flat	3 x 8	1 x 7	1x5.5	1x5.5	30°	0.44
43	HT10002047	R1431-43725-28/59-45-53	Flat	5 x 9	2 x 8	1x6	1x6	35°	0.44
43	HT10002048	R1431-43725-29/59-42-43	Flat	5 x 9	2 x 9	1x6	1x6	35°	0.44
43	HT10002049	R1431-43723-19/39-42-53	Flat	3 x 9	1 x 9	1x6	1x6	35°	0.44
43	HT10002050	R1431-43725-19/39-42-53	Flat	3 x 9	1 x 9	1x6	1x6	35°	0.44
43	HT10002051	R1431-43725-29/59-45-51	Flat	5 x 9	2 x 9	1x5	1x7	35°	0.44
44	HT10002052	1431-44723-28/39-42-53	Flat	3 x 9	2 x 8	1x5.5	1x5.5	35°	0.45
45	HT10002053	R1431-45725-38/69-42-53	Flat	6 x 9	3 x 8	1x6	3x4.5	30°	0.46
51	HT10002054	R1431-51723-210/511-45-31	Flat	5 x 11	2 x 10	1x6	1x6	35°	0.52

Integral and Taper Rod

TH Thread Products

Shank Adapter

DTH Hammer

DTH Bit

DTH Pipe

Rotary Tools



TH Thread Products

R25 | R28 | R32 | RT38 | T45 | T51
GT60 | ST58 | ST68

R25

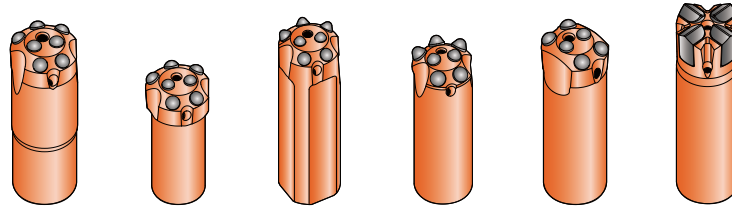

Drill Bits

Dia	Product No.	Product Name	Product Code	Face Type	Buttons		Flushing		Angle	Weight (kg)
					Guage No. X Size (mm)	Center No. X Size (mm)	Guage No. X Size (mm)	Center No. X Size (mm)	Guage Buttons	

Normal Skirt, Spherical Buttons

35	HT20001000	Thread bit	1431-35R25-27/58-50-41	Flat	5 x 8	2 x 7	2 x 5	2 x 4.5	35°	0.40
38	HT20001001	Thread bit	1431-38R25-27/59-50-41	Flat	5 x 9	2 x 7	1 x 6	1 x 5	40°	0.50
41	HT20001002	Thread bit	1431-41R25-28/59-50-41	Flat	5 x 9	2 x 8	2 x 5	1 x 5	35°	0.60
45	HT20001003	Thread bit	1431-45R25-38/69-50-41	Flat	6 x 9	3 x 8	1 x 5	3 x 5	30°	0.60
48	HT20001004	Thread bit	1431-48R25-29/510-50-41	Flat	5 x 10	2 x 9	2 x 5	1 x 5	35°	0.70
51	HT20001005	Thread bit	1431-51R25-210/511-50-41	Flat	5 x 11	2 x 10	2 x 6	1 x 6	35°	1.00
51	HT20001006	Thread bit	1431-51R25-39/610-50-41	Flat	6 x 10	3 x 9		3 x 6	35°	1.00
51	HT20001007	Thread bit	1431-51R25-210/412-50-41	Flat	4 x 12	2 x 10	1 x 6	1 x 6	35°	1.00
65	HT20001008	Thread bit	1431-65R25-410/810-50-41	Flat	8 x 10	4 x 10		2 x 9	35°	1.60

Normal Skirt, Balistic Buttons

33	HT20001009	Thread bit	1431-33R25-27/57-50-51	Flat	5 x 7	2 x 7	1 x 5	1 x 5	35°	0.40
37	HT20001010	Thread bit	1431-37R25-27/58-50-51	Flat	5 x 8	2 x 7	1 x 5	1 x 5	35°	0.50
38	HT20001011	Thread bit	1431-38R25-28/59-50-51	Flat	5 x 9	2 x 8	1 x 6	1 x 5	40°	0.50
38	HT20001012	Thread bit	1431-38R25-28/58-50-51	Flat	5 x 8	2 x 8	2 x 5	1 x 5	35°	0.50
41	HT20001013	Thread bit	1431-41R25-28/59-50-51	Flat	5 x 9	2 x 8	2 x 5	1 x 5	35°	0.60
45	HT20001014	Thread bit	1431-45R25-29/510-50-51	Flat	5 x 10	2 x 9	2 x 5	1 x 5	30°	0.60
45	HT20001015	Thread bit	1431-45R25-38/69-50-51	Flat	6 x 9	3 x 8	1 x 5	3 x 5	30°	0.60
76	HT20001016	Thread bit	1441-76R25-113/913-50-51	Dome	13 x 9	1 x 13	1 x 6	2 x 7	35°	2.00

Retrac Long Skirt, Spherical Buttons

51	HT20001017	Thread bit	1531-51R25-39/610-45-31	Flat	6 x 10	3 x 9		3 x 6	30°	1.40
55	HT20001018	Thread bit	1531-55R25-39/610-45-31	Flat	6 x 10	3 x 9		3 x 6	30°	1.50
64	HT20001019	Thread bit	1531-64R25-410/810-45-31	Flat	8 x 10	4 x 10		2 x 8	35°	2.20

Cross Bits

Dia	Product No.	Product Name	Product Code	Face Type	Insert		Flushing		Angle	Weight (kg)
					Width (mm)	Height (mm)	Guage No. X Size	Center No. X Size	Guage Buttons	
35	HT20001020	Cross bit	1221-35R25-12/8-40-22	Cross	8	12	2 x 5	1 x 6		0.50
38	HT20001021	Cross bit	1221-38R25-12/8-40-22	Cross	8	12	2 x 5.5	1 x 6		0.60
41	HT20001022	Cross bit	1221-41R25-16/10-40-22	Cross	10	16	2 x 6	1 x 6		0.70
45	HT20001023	Cross bit	1221-45R25-14/8-42-22	Cross	8	14	2 x 6	1 x 6		0.80
51	HT20001024	Cross bit	1221-51R25-14/8-42-21	Cross	8	14	2 x 6	1 x 7		1.10

Integral and Taper Rod

TH Thread Products

Shank Adapter

DTH Hammer

DTH Bit

DTH Pipe

Rotary Tools

Drifter Rods

R32 (1 1/4") Hex 25 mm(1") R25 (1")

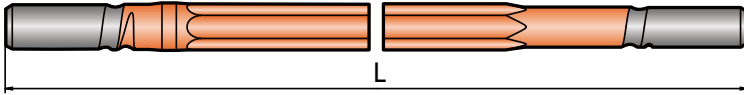

Length	Product No.	Product Name	Product Code	Thread		Weight (kg)
				Bit End	Shank End	
1830	HT20001025	Thread Rod	22H25-R25/R32-1830-23	R25	R32	
2100	HT20001026	Thread Rod	22H25-R25/R32-2100-23	R25	R32	
2400	HT20001027	Thread Rod	22H25-R25/R32-2400-23	R25	R32	
2475	HT20001028	Thread Rod	22H25-R25/R32-2475-23	R25	R32	
2700	HT20001029	Thread Rod	22H25-R25/R32-2700-23	R25	R32	
2875	HT20001030	Thread Rod	22H25-R25/R32-2875-23	R25	R32	
3090	HT20001031	Thread Rod	22H25-R25/R32-3090-23	R25	R32	
3430	HT20001032	Thread Rod	22H25-R25/R32-3430-23	R25	R32	
3700	HT20001033	Thread Rod	22H25-R25/R32-3700-23	R25	R32	

Extension Rods

R25 (1") hex. rod

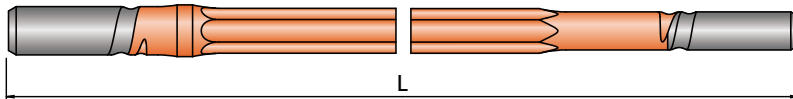

Length	Product No.	Product Name	Product Code	Thread		Weight (kg)
				Bit End	Shank End	
600	HT20001034	Thread rod	23H25-R25-600-23	R25	R25	3.00
915	HT20001035	Thread rod	23H25-R25-915-23	R25	R25	3.90
1220	HT20001036	Thread rod	23H25-R25-1220-23	R25	R25	5.20
1450	HT20001037	Thread rod	23H25-R25-1450-40	R25	R25	6.20
1525	HT20001038	Thread rod	23H25-R25-1525-40	R25	R25	6.50
1570	HT20001039	Thread rod	23H25-R25-1570-23	R25	R25	6.70
1750	HT20001040	Taper rod	23H25-R25-1750-40	R25	R25	7.40
1790	HT20001041	Thread rod	23H25-R25-1790-40	R25	R25	7.60
1830	HT20001042	Thread rod	23H25-R25-1830-23	R25	R25	7.70
2770	HT20001043	Thread rod	23H25-R25-2770-23	R25	R25	11.80

R25

Speed Rod

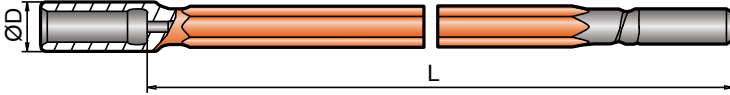

Length	Product No.	Product Name	Product Code	Thread		Weight (kg)
				Bit End	Shank End	
610	HT20001044	Thread rod	24H25-R25/35-0610-23	R25	R25	3.10
1220	HT20001045	Thread rod	24H25-R25/35-1220-23	R25	R25	5.20

Couplings



Length	Product No.	Product Name	Product Code	Thread	Length	Weight (kg)
35	HT20001046	Coupling	31-R25-35-150-23	R25	150	0.8

R28

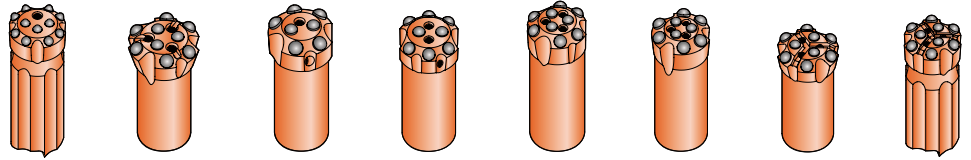

Drill Bits

Dia	Product No.	Product Name	Product Code	Face Type	Buttons		Flushing		Angle	Weight (kg)
					Guage No. X Size (mm)	Center No. X Size (mm)	Guage No. X Size (mm)	Center No. X Size (mm)	Guage Buttons	

Normal Skirt, Spherical Buttons

37	HT30001000	Thread bit	1431-37R28-27/59-50-41	Flat	5 x 9	2 x 7	1 x 5	1 x 5	35°	0.50
38	HT30001001	Thread bit	1431-38R28-28/58-50-41	Flat	5 x 8	2 x 8	2 x 5	1 x 5	35°	0.50
38	HT30001002	Thread bit	1431-38R28-27/59-50-41	Flat	5 x 9	2 x 7	1 x 6	1 x 5	35°	0.50
41	HT30001003	Thread bit	1431-41R28-28/59-50-41	Flat	5 x 9	2 x 8	2 x 5	1 x 5	35°	0.70
43	HT30001004	Thread bit	1431-43R28-28/510-50-41	Flat	5 x 10	2 x 8	1 x 6	1 x 6	25°	0.80
45	HT30001005	Thread bit	1431-45R28-29/510-50-41	Flat	5 x 10	2 x 9	2 x 7	1 x 5	30°	0.90
45	HT30001006	Thread bit	1431-45R28-38/69-50-41	Flat	6 x 9	3 x 8	1 x 5	3 x 5	30°	0.90

Normal Skirt, Balistic Buttons

38	HT30001007	Thread bit	1431-38R28-28/58-50-51	Flat	5 x 8	2 x 8	2 x 5	1 x 5	35°	0.50
38	HT30001008	Thread bit	1431-38R28-28/59-50-51	Flat	5 x 9	2 x 8	1 x 5	1 x 5	35°	0.50
41	HT30001009	Thread bit	1431-41R28-28/59-50-51	Flat	5 x 9	2 x 8	2 x 5	1 x 5	35°	0.70
43	HT30001010	Thread bit	1431-43R28-28/510-50-51	Flat	5 x 1	2 x 8	1 x 6	1 x 6	25°	0.80
45	HT30001011	Thread bit	1431-45R28-38/69-50-51	Flat	6 x 9	3 x 8	1 x 5	3 x 5	30°	0.90
47	HT30001012	Thread bit	1431-47R28-38/69-50-51	Flat	6 x 9	3 x 8	1 x 6	3 x 6	35°	1.00

Drifter Rods

R32 (1¼") Hex 28 mm(1⅞") R28 (1⅞")

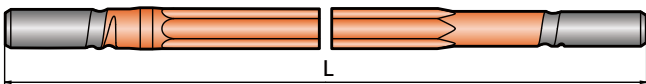

Length	Product No.	Product Name	Product Code	Thread		Weight (kg)
				Bit End	Shank End	
2400	HT30001013	Thread rod	22H28-R28/R32-2400-23	R28	R32	11.90
2435	HT30001014	Thread rod	22H28-R28/R32-2435-23	R28	R32	12.10
2475	HT30001015	Thread rod	22H28-R28/R32-2475-23	R28	R32	12.30
2600	HT30001016	Thread rod	22H28-R28/R32-2600-23	R28	R32	13.60
2700	HT30001017	Thread rod	22H28-R28/R32-2700-23	R28	R32	14.10
2750	HT30001018	Thread rod	22H28-R28/R32-2750-23	R28	R32	14.40
2875	HT30001019	Thread rod	22H28-R28/R32-2875-23	R28	R32	14.60
2975	HT30001020	Thread rod	22H28-R28/R32-2975-23	R28	R32	14.80
3090	HT30001021	Thread rod	22H28-R28/R32-3090-23	R28	R32	15.40
3340	HT30001022	Thread rod	22H28-R28/R32-3340-23	R28	R32	16.60
3400	HT30001023	Thread rod	22H28-R28/R32-3400-23	R28	R32	17.90
3500	HT30001024	Thread rod	22H28-R28/R32-3500-23	R28	R32	18.40
3700	HT30001025	Thread rod	22H28-R28/R32-3700-23	R28	R32	18.50
4310	HT30001026	Thread rod	24H28-R28/R32-4310-23	R28	R32	21.50

R28

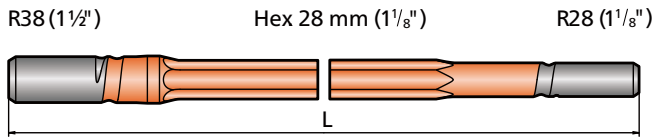

Length	Product No.	Product Name	Product Code	Thread		Weight (kg)
				Bit End	Shank End	
2475	HT30001027	Thread rod	22H28-R28/R38-2475-23	R28	R38	13.00
3700	HT30001028	Thread rod	22H28-R28/R38-3700-23	R28	R38	19.40

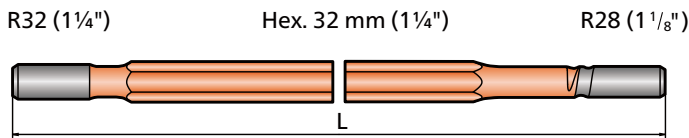

Length	Product No.	Product Name	Product Code	Thread		Weight (kg)
				Bit End	Shank End	
3090	HT30001029	Thread rod	22H32-R28/R32-3090-23	R28	R32	19.80
3700	HT30001030	Thread rod	22H32-R28/R32-3700-23	R28	R32	23.70

Couplings



Length	Product No.	Product Name	Product Code	Thread	Length	Weight (kg)
44	HT30001031	Coupling	31-R32-44-150-23	R32	150	0.90
44	HT30001032	Coupling	31-R32-44-160-23	R32	160	1.00

R32

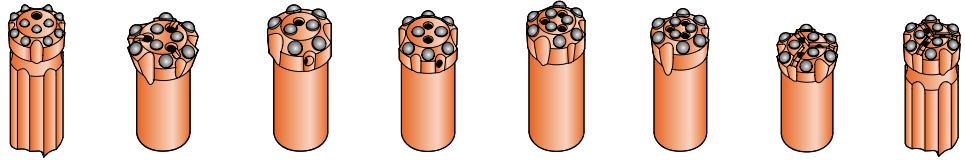

Drill Bits

Dia (mm)	Product No.	Product Name	Product Code	Face Type	Buttons		Flushing		Angle	Weight (kg)
					Guage No. X Size (mm)	Center No. X Size (mm)	Guage No. X Size (mm)	Center No. X Size (mm)	Guage Buttons	

Normal Skirt, Spherical Buttons

41	HT40001001	Thread bit	1431-41R32-29/59-50-41	Flat	5 x 9	2 x 9	2 x 5	1 x 5	35°	0.70
43	HT40001002	Thread bit	1431-43R32-28/510-50-41	Flat	5 x 10	2 x 8	2 x 6	1 x 6	30°	0.70
43	HT40001003	Thread bit	1431-43R32-38/69-50-41	Flat	6 x 9	3 x 8		3 x 5.5	35°	0.70
45	HT40001004	Thread bit	1431-45R32-38/69-50-41	Flat	6 x 9	3 x 8	2 x 5	3 x 5	30°	0.80
45	HT40001005	Thread bit	1431-45R32-38/610-50-41	Flat	6 x 10	3 x 8	1 x 5	3 x 5	30°	0.80
45	HT40001006	Thread bit	1431-45R32-29/511-50-41	Flat	5 x 11	2 x 9	2 x 6	1 x 5	30°	0.80
48	HT40001007	Thread bit	1431-48R32-39/610-50-41	Flat	6 x 10	3 x 9		3 x 6	35°	0.80
48	HT40001008	Thread bit	1431-48R32-38/610-50-41	Flat	6 x 10	3 x 8		3 x 6	35°	0.90
51	HT40001009	Thread bit	1431-51R32-39/610-50-41	Flat	6 x 10	3 x 9	1 x 6	3 x 6	35°	1.00
51	HT40001010	Thread bit	1431-51R32-210/512-50-41	Flat	5 x 12	2 x 10	2 x 6	1 x 6	35°	1.00
57	HT40001011	Thread bit	1431-57R32-211/512-50-41	Flat	5 x 12	2 x 11	1 x 7	1 x 7	35°	1.30
57	HT40001012	Thread bit	1431-57R32-39/610-50-41	Flat	6 x 10	3 x 9		3 x 6	35°	1.30
64	HT40001013	Thread bit	1431-64R32-410/810-50-41	Flat	8 x 10	4 x 10		2 x 9	35°	1.30
64	HT40001014	Thread bit	1431-64R32-311/611-50-41	Flat	6 x 11	3 x 11		3 x 6.5	35°	1.60
76	HT40001015	Thread bit	1431-76R32-412/612-50-41	Flat	6 x 12	4 x 12		2 x 10	35°	2.60
76	HT40001016	Thread bit	1431-76R32-411/812-50-41	Flat	8 x 12	4 x 11	1 x 7	2 x 9	35°	2.60
76	HT40001017	Thread bit	1432-76R32-111/411/812-50-41	Drop Center	8 x 12	5 x 11		4 x 8	35°	2.60
89	HT40001018	Thread bit	1431-89R32-611/812-50-41	Flat	8 x 12	6 x 11	2 x 7	2 x 12	35°	2.60

Normal Skirt, Balistic Buttons

41	HT40001019	Thread bit	1431-41R32-29/59-50-51	Flat	5 x 9	2 x 9	2 x 5	1 x 5	35°	0.70
43	HT40001020	Thread bit	1431-43R32-38/69-50-51	Flat	6 x 9	3 x 8		3 x 5.5	35°	0.70
43	HT40001021	Thread bit	1431-43R32-28/510-50-51	Flat	5 x 10	2 x 8	2 x 6	1 x 6	30°	0.70
45	HT40001022	Thread bit	1431-45R32-28/511-50-51	Flat	5 x 11	2 x 8	2 x 6	2 x 6	30°	0.80
45	HT40001023	Thread bit	1431-45R32-38/69-50-51	Flat	6 x 9	3 x 8	2 x 5	3 x 5	30°	0.80
45	HT40001024	Thread bit	1431-45R32-38/610-50-51	Flat	6 x 10	3 x 8	1 x 5	3 x 5	30°	0.80
45	HT40001025	Thread bit	1431-45R32-29/511-50-51	Flat	5 x 11	2 x 9	2 x 7	1 x 5	30°	0.80
45	HT40001026	Thread bit	1431-45R32-29/411-50-51	Flat	4 x 11	2 x 9	1 x 6	2 x 6	35°	0.80
45	HT40001027	Thread bit	1431-45R32-28/511-50-81	Flat	5 x 11	2 x 8	2 x 6	1 x 6	30°	0.80
48	HT40001028	Thread bit	1431-48R32-29/511-50-51	Flat	5 x 11	2 x 9	2 x 7	1 x 6	30°	0.90
48	HT40001029	Thread bit	1431-48R32-38/610-50-51	Flat	6 x 10	3 x 8	1 x 6	3 x 6	35°	0.90
51	HT40001030	Thread bit	1431-51R32-39/610-50-51	Flat	6 x 10	3 x 9	1 x 5	3 x 6	35°	1.00
51	HT40001031	Thread bit	1431-51R32-210/512-50-51	Flat	5 x 12	2 x 10	2 x 6	1 x 6	35°	1.00
54	HT40001032	Thread bit	1431-54R32-39/610-50-51	Flat	6 x 10	3 x 9		3 x 6	35°	1.00
57	HT40001033	Thread bit	1431-57R32-39/610-50-51	Flat	6 x 10	3 x 9		3 x 6	35°	1.30
60	HT40001034	Thread bit	1431-60R32-212/313-50-61	Flat	3 x 13	2 x 12	1 x 9	1 x 9	43°	1.40
65	HT40001035	Thread bit	1431-65R32-411/612-50-51	Flat	6 x 12	4 x 11	2 x 7	1 x 8	35°	1.60
70	HT40001036	Thread bit	1431-70R32-312/514-50-61	Flat	5 x 14	3 x 12	1 x 7	1 x 10	40°	2.40
76	HT40001037	Thread bit	1431-76R32-411/812-50-51	Flat	8 x 12	4 x 11	1 x 7	2 x 9	35°	2.60

Integral and Taper Rod

TH Thread Products

Shank Adapter

DTH Hammer

DTH Bit

DTH Pipe

Rotary Tools

R32

Retrac Long Skirt, Spherical Buttons

51	HT40001038	Thread bit	1533-51R32-17/38/69-45-31	Drop Center	6 x 9	3 x 8, 1 x 7		3 x 6	30°	1.40
64	HT40001039	Thread bit	1531-64R32-410/810-45-31	Flat	8 x 10	4 x 10	1 x 6	2 x 10	35°	2.20
76	HT40001040	Thread bit	1533-76R32-411/612-50-41	Drop Center	6 x 12	4 x 11		3 x 9	35°	3.50

Retrac Long Skirt, Ballistic Buttons

48	HT40001041	Thread bit	1531-48R32-38/69-45-51	Flat	6 x 9	6 x 9	3 x 8	3 x 6.5	30°	1.20
51	HT40001042	Thread bit	1531-51R32-39/610-45-51	Flat	8 x 10	6 x 10	3 x 9	3 x 6	30°	1.40
51	HT40001043	Thread bit	1533-51R32-17/38/69-45-51	Drop Center	6 x 12	6 x 9	3 x 8, 1 x 7	3 x 6	30°	1.40
64	HT40001044	Thread bit	1533-64R32-19/310/611-45-51	Drop Center		6 x 11	3 x 10, 1 x 9	3 x 8	30°	2.20

Cross Bits

Dia (mm)	Product No.	Product Name	Product Code	Face Type	Insert		Flushing		Angle	Weight (kg)
					Width (mm)	Height (mm)	Gauge No. X Size	Center No. X Size	Gauge Buttons	
41	HT40001045	Cross bit	1221-41R32-12/8-40-22	R32	8	12	2 x 6	1 x 6		0.70
51	HT40001046	Cross bit	1221-51R32-14/8-42-22	R32	8	14	2 x 6.5	1 x 6		1.20
57	HT40001047	Cross bit	1221-57R32-16/10-42-22	R32	10	16	2 x 6	1 x 6		1.30
60	HT40001048	Cross bit	1221-60R32-16/10-40-22	R32	10	16	2 x 6.5	1 x 8		1.40
64	HT40001049	Cross bit	1221-64R32-16/10-42-22	R32	10	16	2 x 6.5	1 x 8		1.50
76	HT40001050	Cross bit	1221-76R32-26/10-42-22	R32	10	26	4 x 8	1 x 8		1.60
76	HT40001051	Cross bit	1221-76R32-26/12-22-22	R32	12	26	4 x 8	1 x 8		1.60

Reaming Bits

Dia (mm)	Product No.	Product Name	Product Code	Face Type	Buttons		Flushing		Angle	Weight (kg)
					Gauge No. X Size	Center No. X Size	Gauge No. X Size	Center No. X Size	Gauge Buttons	
76	HT40001052	Dome Bit	1441-76R32-113/913-45-51	R32	9 x 13	1 x 13	3 x 7		35°	2.00
89	HT40001053	Dome Bit	1441-89R32-113/1413-45-51	R32	14 x 13	1 x 13	4 x 7		35°	2.60
102	HT40001054	Dome Bit	1441-102R32-112/212/1212-50-41	R32	12 x 12	2 x 12, 1 x 12	2 x 8	3 x 6.5	35°	3.20
102	HT40001055	Dome Bit	1441-102R32-113/1613-45-41	R32	16 x 13	1 x 13	4 x 7		35°	3.20

Drifter Rods

R/T38 (1½")

Hex. 32 mm (1¼")

R32 (1¼")

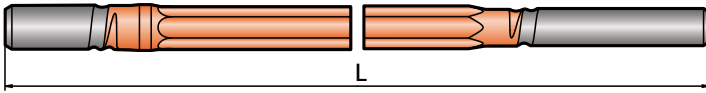

Length	Product No.	Product Name	Product Code	Thread		Weight (kg)
				Bit End	Shank End	
2500	HT40001056	Thread Rod	22H32-R32/R38-2500-23	R32	R38	15.90
3090	HT40001057	Thread Rod	22H32-R32/R38-3090-23	R32	R38	19.70
3090	HT40001058	Thread Rod	22H32-R32/T38-3090-23	R32	T38	19.80
3400	HT40001059	Thread Rod	22H32-R32/R38-3400-23	R32	R38	21.90
3700	HT40001060	Thread Rod	22H32-R32/R38-3700-23	R32	R38	23.50
3700	HT40001061	Thread Rod	22H32-R32/T38-3700-23	R32	T38	23.60
4310	HT40001062	Thread Rod	22H32-R32/R38-4310-23	R32	R38	27.40
4310	HT40001063	Thread Rod	22H32-R32/T38-4310-23	R32	T38	27.30
4975	HT40001064	Thread Rod	22H32-R32/R38-4975-23	R32	R38	31.60

R/T38 (1½")

Hex. 35 mm (1⅜")

R32 (1¼")

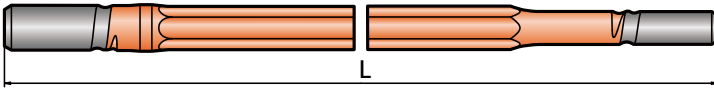

Length	Product No.	Product Name	Product Code	Thread		Weight (kg)
				Bit End	Shank End	
2400	HT40001065	Thread rod	22H35-R32/T38-2400-23	R32	T38	18.50
3090	HT40001066	Thread rod	22H35-R32/R38-3090-23	R32	R38	23.90
3090	HT40001067	Thread rod	22H35-R32/T38-3090-23	R32	T38	23.80
3100	HT40001068	Thread rod	22H35-R32/T38-3100-23	R32	T38	23.90
3700	HT40001069	Thread rod	22H35-R32/R38-3700-23	R32	R38	28.60
3700	HT40001070	Thread rod	22H35-R32/T38-3700-23	R32	T38	28.60
4310	HT40001071	Thread rod	22H35-R32/T38-4310-23	R32	T38	33.60
4500	HT40001072	Thread rod	22H35-R32/T38-4500-23	R32	T38	34.70
4920	HT40001073	Thread rod	22H35-R32/R38-4920-23	R32	R38	38.20
4920	HT40001074	Thread rod	22H35-R32/T38-4920-23	R32	T38	38.30
5530	HT40001075	Thread rod	22H35-R32/T38-5530-23	R32	T38	43.20
6400	HT40001076	Thread rod	22H35-R32/T38-6400-23	R32	T38	49.30

R32

Speed Rod

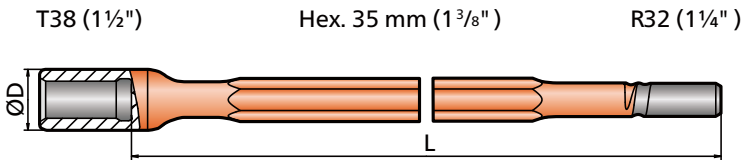

Length	Product No.	Product Name	Product Code	Thread		Weight (kg)
				Bit End	Shank End	
3700	HT40001077	Thread rod	24H35-R32/T38-3700-23	R32	T38	29.80
4310	HT40001078	Thread rod	24H35-R32/T38-4310-23	R32	T38	34.70
5530	HT40001079	Thread rod	24H35-R32/T38-5530-23	R32	T38	43.00
6400	HT40001080	Thread rod	24H35-R32/T38-6400-23	R33	T38	51.00

Couplings



Length	Product No.	Product Name	Product Code	Thread	Length	Weight (kg)
55	HT40001081	Coupling	31-T38-55-170-23	T38	170	1.70
55	HT40001082	Coupling	31-T38-55-190-23	T38	190	1.90
55	HT40001083	Coupling	32-T38-55-190-23	T38	190	1.90
58	HT40001084	Coupling	31-T38-58-190-23	T38	190	2.00
55	HT40001085	Coupling	31-R38-55-170-23	R38	170	1.70
55	HT40001086	Coupling	31-R38-55-180-23	R38	180	2.00

R/T38

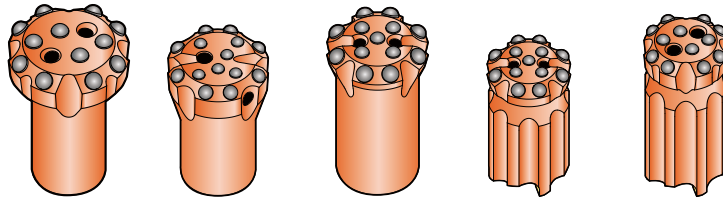

Drill Bits

Dia (mm)	Product No.	Product Name	Product Code	Thread	Face Type	Buttons		Flushing		Angle	Weight (kg)
						Guage No. X Size (mm)	Center No. X Size (mm)	Guage No. X Size (mm)	Center No. X Size (mm)		

Normal Skirt, Spherical Buttons

57	HT50001001	Thread bit	1433-57T38-18/39/610-50-41	T38	Drop Center	6 x 10	3 x 9, 1 x 8		3 x 8	30°	1.50
64	HT50001002	Thread bit	1431-64T38-311/612-50-41	T38	Drop Center	6 x 12	3 x 11		3 x 8	30°	1.70
64	HT50001003	Thread bit	1431-64T38-410/810-50-41	T38	Flat	8 x 10	4 x 10	2 x 6	2 x 10	30°	1.70
64	HT50001004	Thread bit	1433-64T38-110/310/611-50-41	T38	Drop Center	6 x 11	3 x 10, 1 x 10		3 x 8	30°	1.70
70	HT50001005	Thread bit	1431-70T38-410/811-50-41	T38	Flat	8 x 11	4 x 10	2 x 6	2 x 10	35°	1.90
70	HT50001006	Thread bit	1432-70T38-110/410/811-50-41	T38	Drop Center	8 x 11	4 x 10, 1 x 10		4 x 8	30°	1.90
76	HT50001007	Thread bit	1431-76T38-511/813-50-41	T38	Flat	8 x 13	5 x 11	1 x 6	2 x 10	35°	2.40
76	HT50001008	Thread bit	1431-76T38-411/811-50-41	T38	Flat	8 x 11	4 x 11		2 x 11	40°	2.40
76	HT50001009	Thread bit	1431-76T38-412/714-50-41	T38	Flat	7 x 14	4 x 12	1 x 6	2 x 8	35°	2.40
76	HT50001010	Thread bit	1433-76T38-111/311/613-50-41	T38	Drop Center	6 x 13	3 x 11, 1 x 11	1 x 7	3 x 9	35°	2.60
76	HT50001011	Thread bit	1431-76T38-411/812-50-41	T38	Flat	8 x 12	4 x 11	2 x 7	2 x 10	35°	2.40
76	HT50001012	Thread bit	1431-76T38-411/712-50-41	T38	Flat	7 x 12	4 x 11		3 x 9	35°	2.40
89	HT50001013	Thread bit	1431-89T38-611/812-50-41	T38	Flat	8 x 12	6 x 11	2 x 7	2 x 12	35°	3.30
89	HT50001014	Thread bit	1432-89T38-113/413/813-50-41	T38	Drop Center	8 x 13	4 x 13, 1 x 13		4 x 8	35°	3.30
64	HT50001015	Thread bit	1431-64R38-410/810-45-31	R38	Flat	8 x 10	4 x 10	2 x 6	2 x 10	30°	1.70

Normal Skirt, Balistic Buttons

57	HT50001016	Thread bit	1433-57T38-18/39/610-50-51	T38	Drop Center	6 x 10	3 x 9, 1 x 8		3 x 8	30°	1.50
64	HT50001017	Thread bit	1431-64T38-410/810-50-51	T38	Flat	8 x 10	4 x 10	2 x 6	2 x 10	30°	1.70
64	HT50001018	Thread bit	1434-64T38-29/39/611-50-51	T38	Convex	6 x 11	3 x 9, 2 x 9	2 x 7	1 x 10	45°	1.70
64	HT50001019	Thread bit	1431-64T38-311/612-50-51	T38	Flat	6 x 12	3 x 11		3 x 8	30°	1.70
64	HT50001020	Thread bit	1433-64T38-110/310/611-50-51	T38	Drop Center	6 x 11	3 x 10, 1 x 10		3 x 8	35°	1.70
70	HT50001021	Thread bit	1433-70T38-18/310/612-50-51	T38	Drop Center	6 x 12	3 x 10, 1 x 8				1.90
76	HT50001022	Thread bit	1431-76T38-411/812-50-51	T38	Flat	8 x 12	4 x 11	2 x 7	2 x 10	35°	2.40
76	HT50001023	Thread bit	1431-76T38-411/712-50-51	T38	Flat	7 x 12	4 x 11		3 x 9	35°	2.40
76	HT50001024	Thread bit	1433-76T38-110/312/614-50-51	T38	Drop Center	6 x 14	3 x 12, 1 x 10	1 x 7	3 x 9	35°	2.60
89	HT50001025	Thread bit	1431-89T38-611/812-50-51	T38	Flat	8 x 12	6 x 11	2 x 7	2 x 12	35°	3.30
89	HT50001026	Thread bit	1433-89T38-210/312/614-50-51	T38	Drop Center	6 x 14	3 x 12, 2 x 10		3 x 10	35°	3.30
102	HT50001027	Thread bit	1431-102T38-612/814-50-51	T38	Flat	8 x 14	6 x 12		2 x 13	35°	4.40
64	HT50001028	Thread bit	1431-64R38-410/810-50-51	R38	Flat	8 x 10	4 x 10	2 x 6	2 x 10	30°	1.70
64	HT50001029	Thread bit	1433-64R38-110/310/611-50-51	R38	Drop Center	6 x 11	3 x 10, 1 x 10	2 x 6	2 x 10	35°	1.90
76	HT50001030	Thread bit	1432-76R38-111/411/811-50-51	R38	Drop Center	8 x 11	4 x 11, 1 x 11		4 x 8	35°	2.60
76	HT50001031		1431-76R38-411/812-50-51	R38	Flat	8 x 12	4 x 11		2 x 11	35°	2.40

Normal Skirt, Speed Bits

76	HT50001032	Thread bit	1431-76T38-411/712-50-81	T38	Flat	7 x 12	4 x 11		3 x 9	35°	2.40
----	------------	------------	--------------------------	-----	------	--------	--------	--	-------	-----	------

Drill Bits

Dia (mm)	Product No.	Product Name	Product Code	Thread	Face Type	Buttons		Flushing		Angle	Weight (kg)
						Guage No. X Size (mm)	Center No. X Size (mm)	Guage No. X Size (mm)	Center No. X Size (mm)	Guage Buttons	

Retrac Long Skirt, Spherical Buttons

64	HT50001033	Thread bit	1533-64T38-19/410/810-50-41	T38	Drop Center	8 x 10	4 x 10, 1 x 9		3 x 9	35°	2.20
64	HT50001034	Thread bit	1531-64T38-410/810-50-41	T38	Flat	8 x 10	4 x 10	1 x 6	2 x 10	30°	2.20
64	HT50001035	Thread bit	1533-64T38-110/310/611-50-41	T38	Drop Center	6 x 11	3 x 10, 1 x 10		3 x 9	35°	2.20
76	HT50001036	Thread bit	1533-76T38-111/411/811-50-41	T38	Drop Center	8 x 11	4 x 11, 1 x 11	1 x 7	4 x 9.5	30°	3.30
76	HT50001037	Thread bit	1531-76T38-411/812-50-41	T38	Flat	8 x 12	4 x 11	2 x 7	2 x 10	35°	3.30
89	HT50001038	Thread bit	1531-89T38-611/812-50-41	T38	Flat	8 x 12	6 x 11	1 x 6	2 x 11	35°	4.80
89	HT50001039	Thread bit	1533-89T38-29/412/812-50-41	T38	Drop Center	8 x 12	4 x 12, 2 x 9	1 x 7	4 x 10	35°	4.80
102	HT50001040	Thread bit	1531-102T38-612/813-50-41	T38	Flat	8 x 13	6 x 12	2 x 7	2 x 13	35°	5.70
64	HT50001041	Thread bit	1531-64R38-410/810-50-41	R38	Flat	8 x 10	4 x 10	1 x 6	2 x 10	30°	2.20
64	HT50001042	Thread bit	1533-64R38-110/310/611-50-41	R38	Drop Center	6 x 11	3 x 10, 1 x 10		3 x 9	30°	2.20

Retrac Long Skirt, Ballistic Buttons

57	HT50001043	Thread bit	1533-57T38-17/38/69-50-51	T38	Drop Center	6 x 9	3 x 8, 1 x 7		3 x 7.5	35°	1.70
64	HT50001044	Thread bit	1533-64T38-110/310/611-50-51	T38	Drop Center	6 x 11	3 x 10, 1 x 10		3 x 9	35°	2.20
64	HT50001045	Thread bit	1532-64T38-19/410/810-50-51	T38	Drop Center	8 x 10	4 x 10, 1 x 9	1 x 6	4 x 8	30°	2.20
76	HT50001046	Thread bit	1533-76T38-111/311/613-50-51	T38	Drop Center	6 x 13	3 x 11, 1 x 11		3 x 9	35°	3.30
76	HT50001047	Thread bit	1531-76T38-411/812-50-51	T38	Flat	8 x 12	4 x 11		2 x 10	35°	3.30
76	HT50001048	Thread bit	1533-76T38-110/411/811-50-51	T38	Drop Center	8 x 11	4 x 11, 1 x 10	1 x 7	4 x 9.5	30°	3.30
76	HT50001049	Thread bit	1533-76T38-19/312/614-50-51	T38	Drop Center	6 x 14	3 x 12, 1 x 9	1 x 7	3 x 7.5	35°	3.30
89	HT50001050	Thread bit	1533-89T38-29/412/812-50-51	T38	Drop Center	8 x 12	4 x 12, 2 x 9	1 x 7	4 x 10	35°	4.80
89	HT50001051	Thread bit	1531-89T38-612/913-50-51	T38	Flat	9 x 13	6 x 12		3 x 10	35°	4.80

Retrac Short Skirt, Spherical Buttons

64	HT50001052	Thread bit	1632-64T38-59/810-45-31	T38	Drop Center	8 x 10	4 x 9, 1 x 9		4 x 8	30°	2.20
64	HT50001053	Thread bit	1631-64T38-311/612-45-41	T38	Flat	6 x 12	3 x 11		3 x 8	30°	2.20
70	HT50001054	Thread bit	1632-70T38-510/811-45-31	T38	Drop Center	8 x 11	4 x 10, 1 x 10		4 x 8	35°	2.40
76	HT50001055	Thread bit	1632-76T38-511/812-45-41	T38	Drop Center	8 x 12	4 x 11, 1 x 11		4 x 9	30°	3.30

Retrac Short Skirt, Ballistic Buttons

57	HT50001056	Thread bit	1632-57T38-17/38/69-45-51	T38	Drop Center	6 x 9	3 x 8, 1 x 7		3 x 7	35°	1.50
60	HT50001057	Thread bit	1632-60T38-59/810-45-51	T38	Drop Center	8 x 10	4 x 9, 1 x 9		4 x 7	30°	1.90
64	HT50001058	Thread bit	1632-64T38-59/810-45-51	T38	Drop Center	9 x 10	4 x 9, 1 x 9		4 x 8	30°	2.20
70	HT50001059	Thread bit	1632-70T38-510/811-45-51	T38	Drop Center	8 x 11	4 x 10, 1 x 10		4 x 8	35°	2.40

R/T38

Cross Bits

Dia (mm)	Product No.	Product Name	Product Code	Thread	Face Type	Insert		Flushing		Angle	Weight (kg)
						Width Size (mm)	Height Size (mm)	Gauge No. X Size (mm)	Center No. X Size (mm)	Gauge Buttons	
76	HT50001060	Cross bit	1321-76T38-26/12-22-22	T38	Cross	12	26	2 x 8	1 x 14		2.50
89	HT50001061	Cross bit	1321-89T38-25/13-22-22	T38	Cross	13	25	4 x 9	1 x 8		2.80

Extension Rods

R/T38 (1½") round rod

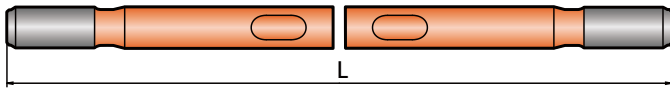

Length	Product No.	Product Name	Product Code	Bit End	Wrench Flat	Weight (kg)
1830	HT50001062	Thread rod	23R39-T38-1830-23	T38		15.00
2600	HT50001063	Thread rod	23R39-T38B-2600-23	T38	Y	21.30
3050	HT50001064	Thread rod	23R39-T38-3050-23	T38		24.80
3050	HT50001065	Thread rod	23R39-T38B-3050-23	T38	Y	24.80
3660	HT50001066	Thread rod	23R39-T38-3660-23	T38		29.00
3965	HT50001067	Thread rod	23R39-T38-3965-23	T38		32.50
4270	HT50001068	Thread rod	23R39-T38B-4270-23	T38	Y	35.00
4500	HT50001069	Thread rod	23R39-T38-4500-23	T38		36.90
1220	HT50001070	Thread rod	23R39-R38B-1220-23	R38	Y	9.90
1220	HT50001071	Thread rod	23R39-R38-1220-23	R38		9.90
1525	HT50001072	Thread rod	23R39-R38-1525-23	R38		12.30
1830	HT50001073	Thread rod	23R39-R38-1830-23	R38		14.80
1830	HT50001074	Thread rod	23R39-R38B-1830-23	R38	Y	14.80
2450	HT50001075	Thread rod	23R39-R38B-2450-23	R38	Y	19.80
3050	HT50001076	Thread rod	23R39-R38-3050-23	R38		24.70
3660	HT50001077	Thread rod	23R39-R38B-3660-23	R38	Y	29.60

R/T38

Speed Rod

R/T38 (1½") round speedrod

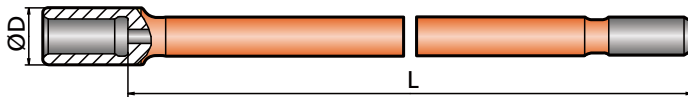

Length	Product No.	Product Name	Product Code	Bit End	Wrench Flat	Weight (kg)
915	HT50001078	Thread rod	24R39-T38/57-915-23	T38		8.30
915	HT50001079	Thread rod	24R39-T38/57B-915-23	T38	Y	8.30
1000	HT50001080	Thread rod	24R39-T38/57B-1000-23	T38	Y	9.10
1220	HT50001081	Thread rod	24R39-T38/57-1220-23	T38		11.10
1220	HT50001082	Thread rod	24R39-T38/57B-1220-23	T38	Y	11.10
1525	HT50001083	Thread rod	24R39-T38/57-1525-23	T38		13.30
1525	HT50001084	Thread rod	24R39-T38/57B-1525-23	T38	Y	13.30
1830	HT50001085	Thread rod	24R39-T38/57-1830-23	T38		15.80
1830	HT50001086	Thread rod	24R39-T38/57B-1830-23	T38	Y	15.80
3050	HT50001087	Thread rod	24R39-T38/57-3050-23	T38		26.30
3050	HT50001088	Thread rod	24R39-T38/57B-3050-23	T38	Y	26.30
3660	HT50001089	Thread rod	24R39-T38/57-3660-23	T38		31.50
3660	HT50001090	Thread rod	24R39-T38/57B-3660-23	T38	Y	31.50
4270	HT50001091	Thread rod	24R39-T38/57-4270-23	T38		36.90
5100	HT50001092	Thread rod	24R39-T38/57B-5100-23	T38	Y	44.10

Guide rod

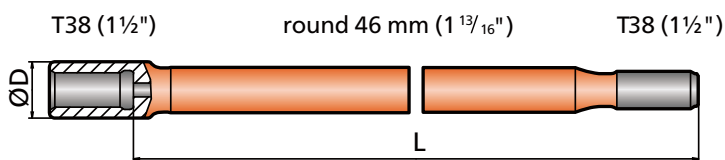

Length	Product No.	Product Name	Product Code	Thread	Wrench Flat	Weight (kg)
1220	HT50001093	Thread rod	24R46-T38/57-1220-23	T38		15.00
1830	HT50001094	Thread rod	24R46-T38/57-1830-23	T38		22.40
2220	HT50001095	Thread rod	24R46-T38/57-2220-23	T38		27.20

R/T38

Couplings



Dia	Product No.	Product Name	Product Code	Thread	Length	Weight (kg)
55	HT50001096	Coupling	31-T38-55-170-23	T38	170	1.50
55	HT50001097	Coupling	31-T38-55-170-42	T38	170	1.50
55	HT50001098	Coupling	31-T38-55-190-23	T38	190	1.70
55	HT50001099	Coupling	32-T38-55-190-23	T38	190	1.70
58	HT50001100	Coupling	31-T38-58-190-23	T38	190	1.70
55	HT50001101	Coupling	31-R38-55-170-23	R38	170	1.70
55	HT50001102	Coupling	31-R38-55-180-23	R38	180	2.00

T45

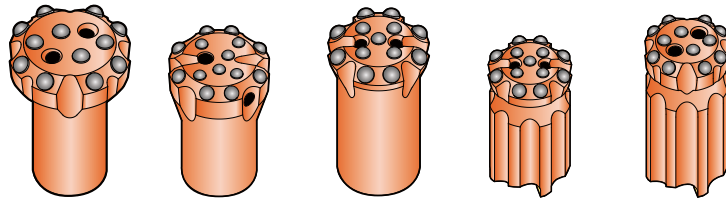

Drill Bits

Dia (mm)	Product No.	Product Name	Product Code	Thread	Face Type	Buttons		Flushing		Angle	Weight (kg)
						Guage No. X Size (mm)	Center No. X Size (mm)	Guage No. X Size (mm)	Center No. X Size (mm)	Guage Buttons	

Normal Skirt, Spherical Buttons

70	HT60001001	Thread bit	1432-70T45-110/410/811-50-41	T45	Drop Center	8 x 11	4 x 10, 1 x 10		3 x 9	29°	2.60
76	HT60001002	Thread bit	1432-76T45-111/411/812-50-41	T45	Drop Center	8 x 12	4 x 11, 1 x 11		4 x 9	30°	2.60
76	HT60001003	Thread bit	1431-76T45-611/811-50-41	T45	Flat	8 x 11	6 x 11		2 x 12	35°	2.60
76	HT60001004	Thread bit	1431-76T45-411/613-50-41	T45	Flat	6 x 13	4 x 11		2 x 11	35°	2.50
76	HT60001005	Thread bit	1431-76T45-411/811-50-41	T45	Flat	8 x 11	4 x 11		2 x 12	40°	2.60
76	HT60001006	Thread bit	1431-76T45-411/812-50-41	T45	Flat	8 x 12	4 x 11	1 x 7	2 x 11	35°	2.60
76	HT60001007	Thread bit	1431-76T45-411/813-50-41	T45	Flat	8 x 13	4 x 11		2 x 11	35°	2.70
76	HT60001008	Thread bit	1431-76T45-412/812-50-41	T45	Flat	8 x 12	4 x 12	1 x 9.5	2 x 10	35°	2.60
80	HT60001009	Thread bit	1431-80T45-511/812-50-41	T45	Flat	8 x 12	5 x 11		2 x 11	35°	2.80
85	HT60001010	Thread bit	1431-85T45-412/813-50-41	T45	Flat	8 x 13	4 x 12	2 x 7	2 x 12	35°	4.50
89	HT60001011	Thread bit	1432-89T45-113/413/813-50-41	T45	Drop Center	8 x 13	4 x 13, 1 x 13		4 x 9.5	35°	3.00
89	HT60001012	Thread bit	1431-89T45-611/812-50-41	T45	Flat	8 x 12	6 x 11	1x 6	2 x 13	35°	4.60
89	HT60001013	Thread bit	1431-89T45-613/814-50-41	T45	Flat	8 x 14	6 x 13		2 x 13	35°	5.00
89	HT60001014	Thread bit	1431-89T45-512/813-50-41	T45	Flat	8 x 13	5 x 12	2x 6	2 x 13	35°	4.60
102	HT60001015	Thread bit	1431-102T45-612/814-50-41	T45	Flat	8 x 14	6 x 12		2 x 14	35°	4.50
102	HT60001016	Thread bit	1433-102T45-113/413/814-50-41	T45	Drop Center	8 x 14	4 x 13, 1 x 13		4 x 11	35°	3.40

Normal Skirt, Balistic Buttons

76	HT60001017	Thread bit	1431-76T45-412/812-50-51	T45	Flat	8 x 12	4 x 12	1 x 9.5	2 x 10	35°	2.60
76	HT60001018	Thread bit	1432-76T45-111/411/811-50-51	T45	Drop Center	8 x 11	4 x 11, 1 x 11		4 x 9	35°	2.60
76	HT60001019	Thread bit	1434-76T45-210/410/811-50-51	T45	Convex	8 x 11	4 x 10, 2 x 10	1 x 7	2 x 10	40°	2.40
85	HT60001020	Thread bit	1431-85T45-412/813-50-51	T45	Flat	8 x 13	4 x 12	2 x 7	2 x 12	35°	4.50
89	HT60001021	Thread bit	1431-89T45-512/813-50-51	T45	Flat	8 x 13	5 x 12	2x 6	2 x 13	35°	4.60
89	HT60001022	Thread bit	1431-89T45-611/812-50-51	T45	Flat	8 x 12	6 x 11	1x 6	2 x 13	35°	4.60
89	HT60001023	Thread bit	1432-89T45-112/412/812-50-51	T45	Drop Center	8 x 12	4 x 12, 1 x 12		4 x 9.5	36°	3.00
89	HT60001024	Thread bit	1433-89T45-210/312/614-50-51	T45	Drop Center	6x14	3 x 12, 2 x 10		4 x 9	35°	3.00
102	HT60001025	Thread bit	1433-102T45-213/413/813-50-51	T45	Drop Center	8 x 13	4 x 13, 2 x 13		4 x 13	35°	3.40

Normal Skirt, Speed Bits

76	HT60001026	Thread bit	1431-76T45-412/812-50-81	T45	Flat	8 x 12	4 x 12	2 x 9.5	2 x 11	35°	2.70
89	HT60001027	Thread bit	1431-89T45-413/813-50-51/41	T45	Flat	8 x 13	4 x 13	1x 6	2 x 13	35°	4.60

Retrac Long Skirt, Spherical Buttons

76	HT60001028	Thread bit	1531-76T45-312/612-50-41	T45	Flat	6 x 12	3 x 12		3 x 10	35°	2.80
76	HT60001029	Thread bit	1531-76T45-411/811-50-41	T45	Flat	8 x 11	4 x 11		2 x 12	40°	2.80
76	HT60001030	Thread bit	1531-76T45-511/812-50-41	T45	Flat	8 x 12	5 x 11		2 x 12	35°	2.80
76	HT60001031	Thread bit	1533-76T45-110/411/811-50-41	T45	Drop Center	8 x 11	4 x 11, 1 x 10		4 x 9.5	30°	3.10
85	HT60001032	Thread bit	1531-85T45-412/813-50-41	T45	Flat	8 x 13	4 x 12		2 x 12	35°	4.70
89	HT60001033	Thread bit	1533-89T45-211/311/613-50-41	T45	Drop Center	6 x 13	3 x 11, 2 x 11		3 x 11	35°	4.80
89	HT60001034	Thread bit	1531-89T45-613/813-50-41	T45	Flat	8 x 13	6 x 13	1 x 7	2 x 12	35°	4.80
89	HT60001035	Thread bit	1531-89T45-711/911-50-41	T45	Flat	9 x 11	7 x 11		3 x 11	35°	4.80
89	HT60001036	Thread bit	1533-89T45-29/412/812-50-41	T45	Drop Center	8 x 12	4 x 12, 2 x 9	1 x 7	4 x 11	35°	4.70
102	HT60001037	Thread bit	1533-102T45-113/413/814-50-41	T45	Drop Center	8 x 14	4 x 13, 1 x 13		4 x 11	35°	7.80
115	HT60001038	Thread bit	1533-115T45-213/413/814-50-41	T45	Drop Center	8 x 14	4 x 13, 2 x 13		4 x 12	35°	9.00

T45

Drill Bits

Dia (mm)	Product No.	Product Name	Product Code	Thread	Face Type	Buttons		Flushing		Angle	Weight (kg)
						Gauge No. X Size (mm)	Center No. X Size (mm)	Gauge No. X Size (mm)	Center No. X Size (mm)	Gauge Buttons	

Retrac Long Skirt, Ballistic Buttons

70	HT60001039	Thread bit	1533-70T45-18/411/811-50-51	T45	Drop Center	8 x 11	4 x 11, 1 x 8		4 x 9	30°	2.60
76	HT60001040	Thread bit	1531-76T45-411/811-50-51	T45	Flat	8 x 11	4 x 11		2 x 12	40°	2.80
76	HT60001041	Thread bit	1531-76T45-411/812-50-51	T45	Flat	8 x 12	4 x 11	2 x 7	2 x 10	35°	2.80
76	HT60001042	Thread bit	1533-76T45-111/411/811-50-51	T45	Drop Center	8 x 11	4 x 11, 1 x 11	1 x 7	4 x 9.5	30°	3.10
80	HT60001043	Thread bit	1533-80T45-110/411/811-50-51	T45	Drop Center	8 x 11	4 x 11, 1 x 10		4 x 9.5	30°	3.00
85	HT60001044	Thread bit	1531-85T45-412/813-50-51	T45	Flat	8 x 13	4 x 12		2 x 12	35°	4.70
89	HT60001045	Thread bit	1533-89T45-29/412/812-50-51	T45	Drop Center	8 x 12	4 x 12, 2 x 9	1 x 7	4 x 11	35°	4.70
89	HT60001046	Thread bit	1533-89T45-211/311/613-50-51	T45	Drop Center	6 x 13	3 x 11, 2 x 11		3 x 11	35°	4.70
102	HT60001047	Thread bit	1533-102T45-113/413/814-50-51	T45	Drop Center	8 x 14	4 x 13, 1 x 13		4 x 11	35°	7.80

Retrac Short Skirt, Spherical Buttons

76	HT60001048	Thread bit	1632-76T45-111/411/812-50-41	T45	Drop Center	8 x 12	4 x 11, 1 x 11		4 x 9	30°	3.10
89	HT60001049	Thread bit	1633-89T45-29/412/813-50-41	T45	Drop Center	8 x 13	4 x 12, 2 x 9		4 x 9	35°	4.80
89	HT60001050	Thread bit	1632-89T45-113/413/813-50-41	T45	Drop Center	8 x 13	4 x 13, 1 x 13		4 x 9	35°	4.80

Retrac Short Skirt, Ballistic Buttons

70	HT60001051	Thread bit	1632-70T45-110/410/811-50-51	T45	Drop Center	8 x 11	4 x 10, 1 x 10		4 x 8	35°	3.10
76	HT60001052	Thread bit	1632-76T45-111/411/812-50-51	T45	Drop Center	8 x 12	4 x 11, 1 x 11		4 x 9.5	35°	3.10
89	HT60001053	Thread bit	1632-89T45-113/413/813-50-51	T45	Drop Center	8 x 13	4 x 13, 1 x 13		4 x 9	35°	4.80

Extension Rods

T45 (1 3/4") round rod

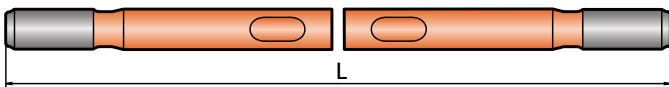

Length	Product No.	Product Name	Product Code	Thread	Wrench Flat	Weight (kg)
3050	HT60001054	Thread rod	23R46-T45-3050-23	T45		34.50
3050	HT60001055	Thread rod	23R46-T45B-3050-23	T45	Y	34.50
3660	HT60001056	Thread rod	23R46-T45-3660-23	T45		41.40
3660	HT60001057	Thread rod	23R46-T45B-3660-23	T45	Y	41.40
4270	HT60001058	Thread rod	23R46-T45-4270-23	T45		48.30
5100	HT60001059	Thread rod	23R46-T45-5100-23	T45		57.70
6095	HT60001060	Thread rod	23R46-T45-6095-23	T46		69.00

T45

Speed Rod

T45 (1 3/4") round speed rod

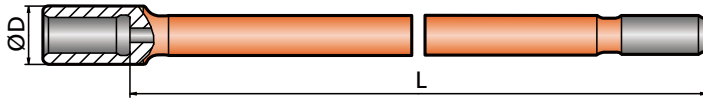

Length	Product No.	Product Name	Product Code	Thread	Wrench Flat	Weight (kg)
1220	HT60001061	Thread rod	24R46-T45/65B-1220-23	T45	Y	14.50
1525	HT60001062	Thread rod	24R46-T45/65B-1525-23	T45	Y	18.20
1830	HT60001063	Thread rod	24R46-T45/65-1830-23	T45		21.50
1830	HT60001064	Thread rod	24R46-T45/65B-1830-23	T45	Y	21.50
2435	HT60001065	Thread rod	24R46-T45/65-2435-23	T45		29.10
3050	HT60001066	Thread rod	24R46-T45/65-3050-23	T45		37.60
3050	HT60001067	Thread rod	24R46-T45/65B-3050-23	T45	Y	37.60
3660	HT60001068	Thread rod	24R46-T45/65-3660-23	T45		43.50
3660	HT60001069	Thread rod	24R46-T45/65B-3660-23	T45	Y	43.50
4000	HT60001070	Thread rod	24R46-T45/65B-4000-23	T45	Y	47.70
4270	HT60001071	Thread rod	24R46-T45/65B-4270-23	T45	Y	51.50
4600	HT60001072	Thread rod	24R46-T45/65-4600-23	T45		54.90

Couplings



Dia	Product No.	Product Name	Product Code	Thread	Length	Weight (kg)
63	HT60001073	Coupling	31-T45-63-210-23	T45	210	2.70
66	HT60001074	Coupling	31-T45-66-210-23	T45	210	3.10

T51

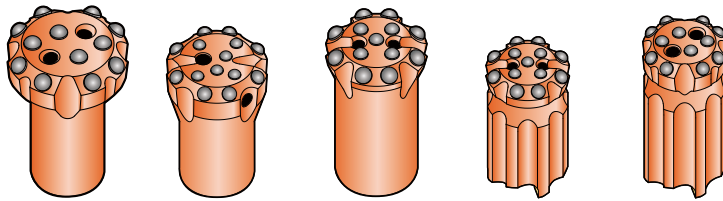

Drill Bits

Dia (mm)	Product No.	Product Name	Product Code	Thread	Face Type	Buttons		Flushing		Angle	Weight (kg)
						Guage No. X Size (mm)	Center No. X Size (mm)	Guage No. X Size (mm)	Center No. X Size (mm)	Guage Buttons	

Normal Skirt, Spherical Buttons

89	HT70001001	Thread bit	1431-89T51-413/813-50-41	T51	Flat	8 x 13	4 x 13		2 x 13	40°	3.50
89	HT70001002	Thread bit	1432-89T51-113/413/813-50-41	T51	Drop Center	8 x 13	4 x 13, 1 x 13		4 x 10	35°	3.60
89	HT70001003	Thread bit	1431-89T51-712/912-50-41	T51	Flat	9 x 12	7 x 12		3 x 11	35°	3.80
89	HT70001004	Thread bit	1431-89T51-512/813-50-81	T51	Flat	8 x 13	5 x 12	1 x 6	2 x 12	35°	3.60
89	HT70001005	Thread bit	1431-89T51-611/812-50-41	T51	Flat	8 x 12	6 x 11		2 x 12	35°	3.70
102	HT70001006	Thread bit	1432-102T51-213/413/813-50-41	T51	Drop Center	8 x 13	4 x 13, 2 x 13		4 x 11	35°	5.30
102	HT70001007	Thread bit	1431-102T51-713/913-50-41	T51	Flat	9 x 13	7 x 13		3 x 12	35°	5.30
102	HT70001008	Thread bit	1431-102T51-612/814-50-41	T51	Flat	8 x 14	6 x 12		2 x 15	35°	5.30
115	HT70001009	Thread bit	1431-115T51-714/816-50-41	T51	Flat	8 x 16	7 x 14		2 x 16	35°	6.10
115	HT70001010	Thread bit	1433-115T51-311/414/814-50-41	T51	Drop Center	8 x 14	4 x 14, 3 x 11		4 x 13	40°	6.00
115	HT70001011	Thread bit	1433-115T51-214/414/816-50-41	T51	Drop Center	8 x 16	4 x 14, 2 x 14		4 x 13	40°	6.00
127	HT70001012	Thread bit	1433-127T51-314/414/814-50-41	T51	Drop Center	8 x 14	4 x 14, 3 x 14		4 x 14	40°	6.80

Normal Skirt, Balistic Buttons

89	HT70001013	Thread bit	1431-89T51-712/912-50-51	T51	Flat	9 x 12	7 x 12		3 x 11	35°	3.80
89	HT70001014	Thread bit	1432-89T51-113/413/813-50-51	T51	Drop Center	8 x 13	4 x 13, 1 x 13		4 x 10	35°	3.60
102	HT70001015	Thread bit	1431-102T51-713/913-50-51	T51	Flat	9 x 13	7 x 13		3 x 12	35°	5.30
102	HT70001016	Thread bit	1433-102T51-213/413/813-50-51	T51	Drop Center	8 x 13	4 x 13, 2 x 13		4 x 13	35°	5.30
102	HT70001017	Thread bit	1431-102T51-512/812-50-61	T51	Flat	8 x 12	5 x 12		4 x 12	35°	5.30
115	HT70001018	Thread bit	1432-115T51-214/414/814-50-51	T51	Drop Center	8 x 14	4 x 14, 2 x 14		4 x 13	40°	6.00
127	HT70001019	Thread bit	1433-127T51-314/414/814-50-51	T51	Drop Center	8 x 14	4 x 14, 3 x 14		4 x 14	40°	6.80

Retrac Long Skirt, Spherical Buttons

89	HT70001020	Thread bit	1531-89T51-712/912-50-41	T51	Flat	9 x 12	7 x 12		3 x 11	35°	5.30
89	HT70001021	Thread bit	1533-89T51-113/413/813-50-41	T51	Drop Center	8 x 13	4 x 13, 1 x 13		4 x 11	35°	4.90
89	HT70001022	Thread bit	1531-89T51-513/813-50-41	T51	Flat	8 x 13	5 x 13		2 x 12	35°	5.30
89	HT70001023	Thread bit	1533-89T51-29/412/812-50-41	T51	Drop Center	8 x 12	4 x 12, 2 x 9	1 x 7	4 x 11	35°	4.90
102	HT70001024	Thread bit	1532-102T51-213/413/814-50-41	T51	Drop Center	8 x 14	4 x 13, 2x 13		4 x 11	35°	7.20
102	HT70001025	Thread bit	1531-102T51-713/913-50-41	T51	Flat	9 x 13	7 x 13		3 x 12	35°	7.00
102	HT70001026	Thread bit	1531-102T51-612/814-50-41	T51	Flat	8 x 14	6 x 12		2 x 14	40°	7.00
115	HT70001027	Thread bit	1533-115T51-213/413/814-50-41	T51	Drop Center	8 x 14	4 x 13, 2 x 13		4 x 13	40°	9.50
127	HT70001028	Thread bit	1533-127T51-313/414/814-50-41	T51	Drop Center	8 x 14	4 x 14, 3 x 13		4 x 14	40°	11.20

Integral and Taper Rod

TH Thread Products

Shank Adapter

DTH Hammer

DTH Bit

DTH Pipe

Rotary Tools

T51

Dia (mm)	Product No.	Product Name	Product Code	Thread	Face Type	Buttons		Flushing		Angle	Weight (kg)
						Guage No. X Size (mm)	Center No. X Size (mm)	Guage No. X Size (mm)	Center No. X Size (mm)	Guage Buttons	

Retrac Long Skirt, Ballistic Buttons

89	HT70001029	Thread bit	1531-89T51-712/912-50-51	T51	Flat	9 x 12	7 x 12		3 x 11	35°	5.30
89	HT70001030	Thread bit	1533-89T51-29/412/812-50-51	T51	Drop Center	8 x 12	4 x 12, 2 x 9	1 x 7	4 x 11	35°	4.90
89	HT70001031	Thread bit	1533-89T51-211/311/613-50-51	T51	Drop Center	6 x 13	3 x 11, 2x 11		3 x 11	35°	4.90
102	HT70001032	Thread bit	1531-102T51-713/913-50-51	T51	Flat	9 x 13	7 x 13		3 x 12	35°	7.00
102	HT70001033	Thread bit	1532-102T51-213/413/814-50-51	T51	Drop Center	8 x 14	4 x 13, 2 x 13		4 x 11	35°	7.20
115	HT70001034	Thread bit	1533-115T51-213/413/814-50-51	T51	Drop Center	8 x 14	4 x 13, 2 x 13		4 x 13	40°	9.50

Retrac Short Skirt, Spherical Buttons

89	HT70001035	Thread bit	1632-89T51-113/413/813-50-41	T51	Drop Center	8 x 13	4 x 13, 1 x 13		4 x 9.5	35°	4.90
102	HT70001036	Thread bit	1632-102T51-213/413/813-50-41	T51	Drop Center	8 x 13	4 x 13, 2 x 13		4 x 11	40°	7.20

Retrac Short Skirt, Ballistic Buttons

89	HT70001037	Thread bit	1632-89T51-113/413/813-50-51	T51	Drop Center	8 x 13	4 x 13, 1 x 13		4 x 10	40°	4.90
102	HT70001038	Thread bit	1632-102T51-213/413/813-50-51	T51	Drop Center	8 x 13	4 x 13, 2 x 13		4 x 11	40°	7.20

Extension Rods

T51 (2") round rod

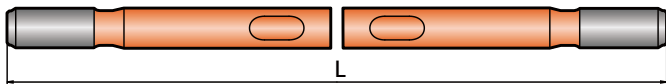

Length	Product No.	Product Name	Product Code	Thread	Wrench Flat	Weight (kg)
3660	HT70001039	Thread rod	23R52-T51-3660-23	T51		51.10
3660	HT70001040	Thread rod	23R52-T51B-3660-23	T51	Y	49.10
4270	HT70001041	Thread rod	23R52-T51-4270-23	T51		59.50
6095	HT70001042	Thread rod	23R52-T51-6095-23	T51		85.10

T51

Speed Rod

T51 (2") round speedrod

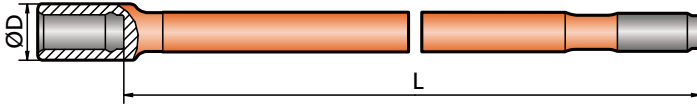

Length	Product No.	Product Name	Product Code	Thread	Wrench Flat	Weight (kg)
3050	HT70001043	Thread rod	24R52-T51/72-3050-23	T51		43.20
3660	HT70001044	Thread rod	24R52-T51/72-3660-23	T51		51.80
3660	HT70001045	Thread rod	24R52-T51/72B-3660-23	T51	Y	55.40
4270	HT70001046	Thread rod	24R52-T51/72-4270-23	T51		67.60
4270	HT70001047	Thread rod	24R52-T51/72B-4270-23	T51	Y	64.00
4600	HT70001048	Thread rod	24R52-T51/72-4600-23	T51		72.80
6095	HT70001049	Thread rod	24R52-T51/72-6095-23	T51		89.50

Couplings



Dia	Product No.	Product Name	Product Code	Thread	Length	Weight (kg)
72	HT70001050	Coupling	31-T51-72-235-23	T51	235	4.10
77	HT70001051	Coupling	31-T51-77-235-23	T51	235	5.20



GT60

Dia	Product No.	Product Name	Product Code	Thread	Face Type	Buttons		Flushing		Angle	Weight (kg)
						Guage No. X Size	Center No. X Size	Guage No. X Size	Center No. X Size	Guage Buttons	

Normal Skirt, Spherical Buttons

102	HTX0001001	Thread bit	1431-102ST68-413/813-50-41	GT60	Flat	9 x 13	9 x 11		3 x 13	35°	6.10
115	HTX0001002	Thread bit	1431-115ST68-413/813-50-41	GT60	Flat	9 x 14	10 x 12		3 x 14	35°	7.60

Retrac Long Skirt, Spherical Buttons

102	HT80001003	Thread bit	1531-102GT60-612/814-50-41	GT60	Flat	10 x 12	8 x 12		4 x 10	35°	6.40
115	HT80001004	Thread bit	1533-115GT60-213/413/814-50-41	GT60	Flat	10 x 14	8 x 14		4 x 10	35°	8.50
127	HT80001005	Thread bit	1533-127GT60-313/414/814-50-41	GT61	Flat						

Retrac Long Skirt, Ballistic Buttons

115	HT80001006	Thread bit	1532-115GT60-213/413/814-50-51	GT60	Flat	9 x 14	10 x 12		3 x 14	40°	9.80
-----	------------	------------	--------------------------------	------	------	--------	---------	--	--------	-----	------

Speed Rod

Length	Product No.	Product Name	Product Code	Thread	OD (mm)	Weight (kg)
3660	HT80001007	Thread rod	24R60-GT60/85-3600-23	GT60	60.00	74.00
4270	HT80001008	Thread rod	24R60-GT60/85-4265-23	GT61	60.00	86.00
6095	HT80001009	Thread rod	24R60-GT60/85-6095-23	GT62	60.00	117.00

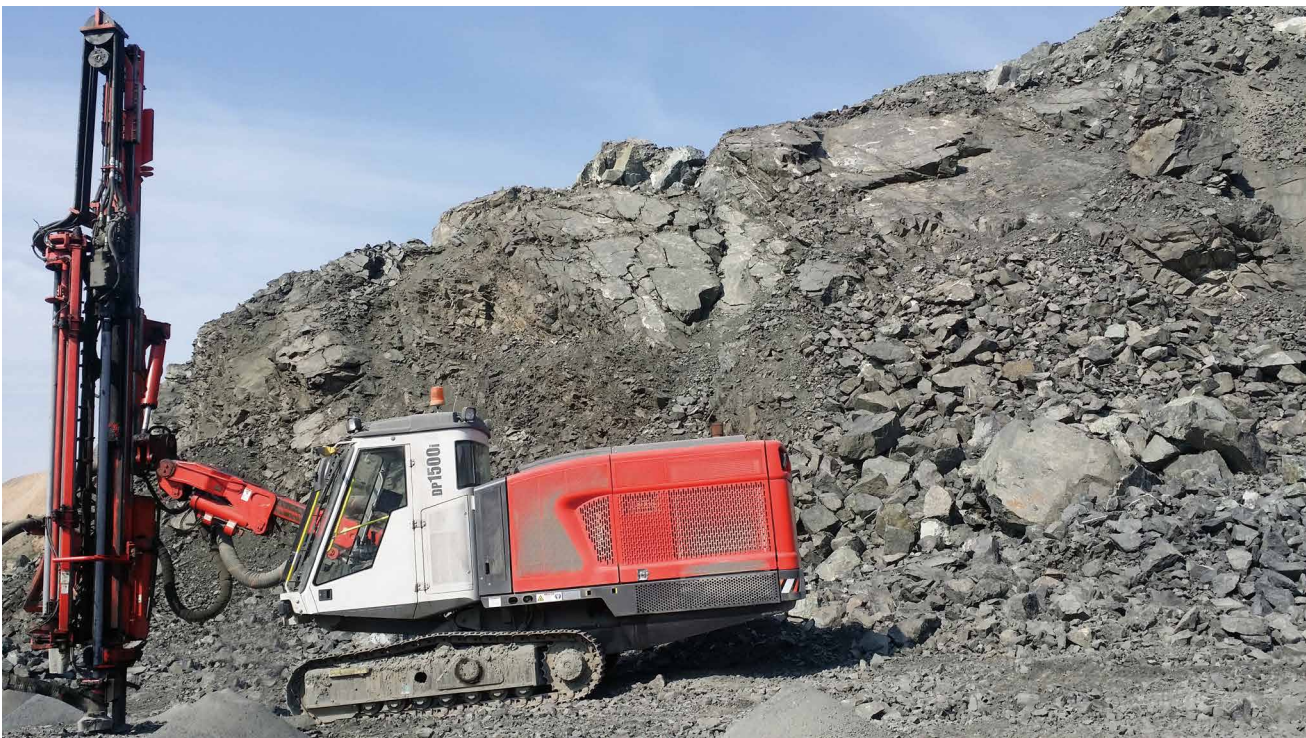

ST58

Dia	Product No.	Product Name	Product Code	Face Type	Buttons		Flushing		Angle	Weight (kg)
					Guage No. X Size	Center No. X Size	Guage No. X Size	Center No. X Size	Guage Buttons	

Normal Skirt, Spherical Buttons

89	HT90001001	Thread bit	1431-89ST58-413/813-50-41	Drop Center	8 x 12	6 x 12		4 x 10	35°	4.00
----	------------	------------	---------------------------	-------------	--------	--------	--	--------	-----	------

Guide Retrac, Ballistic Buttons

89	HT90001002	Thread bit	1531-89ST58-712/912-50-41	Drop Center	10 x 12	4 x 12		3 x 14	35°	4.00
----	------------	------------	---------------------------	-------------	---------	--------	--	--------	-----	------

Tubes

Length	Product No.	Product Name	Product Code	Thread	OD (mm)	Weight (kg)
1525	HT90001003	Thread rod	25G76-ST58-1525-23	ST58	76	33.00
1830	HT90001004	Thread rod	25G76-ST58-1830-23	ST58	76	44.00

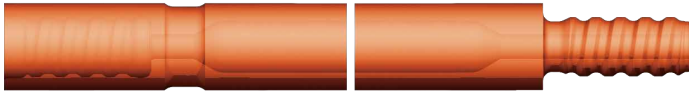

ST68

Dia	Product No.	Product Name	Product Code	Face Type	Buttons		Flushing		Angle	Weight (kg)
					Guage No. X Size	Center No. X Size	Guage No. X Size	Center No. X Size	Guage Buttons	

Normal Skirt, Spherical Buttons

102	HTX0001001	Thread bit	1431-102ST68-413/813-50-41	Drop Center	10 x 12	8 x 12		4 x 10	35°	5.50
115	HTX0001002	Thread bit	1431-115ST68-413/813-50-41	Drop Center	10 x 14	8 x 14		4 x 10	35°	6.20

Guide Retrac, Ballistic Buttons

102	HTX0001003	Thread bit	1531-102ST68-712/912-50-41	Drop Center	10 x 12	8 x 12		4 x 10	35°	6.40
115	HTX0001004	Thread bit	1531-102ST68-712/912-50-41	Drop Center	10 x 14	8 x 14		4 x 10	35°	8.50

Tubes

Length	Product No.	Product Name	Product Code	Thread	OD (mm)	Weight (kg)
1525	HTX0001005	Thread rod	25G87-ST68-1525-23	ST68	87	41.00
1830	HTX0001006	Thread rod	25G87-ST68-1830-23	ST68	87	48.00

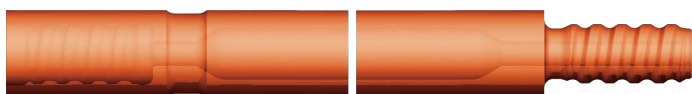





Shank Adapter

SHANK ADAPTER

	Part Number	Thread	Out Diameter	Length	Product Code
Atlas Copco COP 1238					
	38003001-S	T38	38	575	41238-38T38-0575-23
	38003002-S	T38	45	575	41238-45T38-0575-23
	45004001-S	T45	45	575	41238-45T45-0575-23
	38003003-S	T38	38	500	41238-45T45-0500-23
	45004002-S	T45	45	500	41238-45T45-0500-23

Atlas Copco COP 1432, COP 1532, COP 1440, COP 1838 HD/ME					
	32002001-S	R32	38	435	41838-38R32-0435-23
	38003004-S	T38	38	435	41838-38T38-0435-23
	38003005-S	T38	38	525	41838-38T38-0525-23

Atlas Copco COP 1838HE, COP 1850					
	38003006-S	T38	52	565	41838-52T38-0565-23
	45004003-S	T45	52	565	41838-52T45-0565-23
	51005001-S	T51	52	565	41838-52T51-0565-23

Atlas Copco COP 1840 HE, COP 1850					
	38003011-S	T38	52	565	41840-52T38-0565-23
	45004006-S	T45	52	565	41840-52T45-0565-23
	51005004-S	T51	52	565	41840-52T51-0565-23

Sandvik HLX5 ,HLX5T					
	32002002-S	R32	45	500	4HLX5-45R32-0500-23
	38003007-S	T38	45	500	4HLX5-45T38-0500-23
	38003008-S	T38	45	575	4HLX5-45T38-0575-23
	45004004-S	T45	45	500	4HLX5-45T45-0500-23

Sandvik HL700, HL800T					
	38003009-S	T38	52	600	4HL700-52T38-0600-23
	45004005-S	T45	52	600	4HL700-52T45-0600-23
	51005002-S	T51	52	600	4HL700-52T51-0600-23

HL1000PE-65, HL1010PE-65, HL1060T/PE-65, HL1500T/PE-65, HL1560T/PE-65					
	51005003-S	T51	65	760	4H1000-65T51-0760-23
	60005001-S	GT60	65	760	4H1000-65G60-0760-23
	68005001-S	ST68	65	760	4H1000-65S60-0760-23

Furukawa HD712					
	38003010-S	T38	45	620	4HD709-45T38-0620-23

Integral and Taper Rod

TH Thread Products

Shank Adapter

DTH Hammer

DTH Bit

DTH Pipe

Rotary Tools



DTH Hammer

DTH4 Inch | DTH5 Inch
DTH6 Inch | DTH8 Inch

DTH 4 Inch

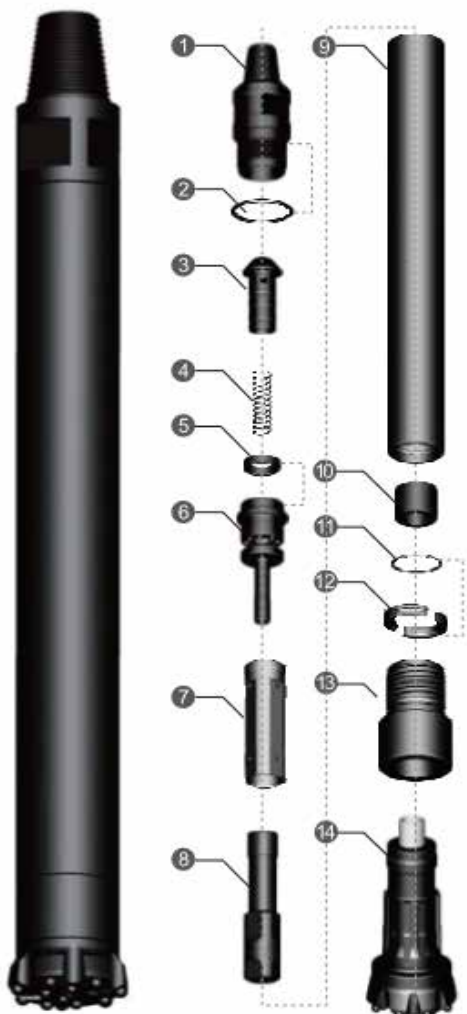

Item	Description	Part Number
1	Top Sub	HD410010001
	Top Sub with Button	HD410010002
2	"O" Ring	HD410010003
3	Check Valve	HD410010004
4	Spring	HD410010005
5	Buffer Ring	HD410010006
6	Air Distributor	HD410010007
7	Internal Cylinder	HD410010008
8	Piston	HD410010009
9	External Cylinder	HD410010010
10	Guide Sleeve	HD410010011
11	"O" Ring of R-Ring	HD410010012
12	Bit Retaining Ring	HD410010013
13	Driver Sub (DHD340A)	HD410010014
14	Drill Bit	See Page

Complete Hammer Product Code	Description	Part Number
62-4-D340-10-G	HRD4 Hammer with DHD340A	HD4100100A

Technical Data

Lenth (W/O Bit)	922mm
Weight(W/O Bit)	38Kg
Out Diameter	100mm
Shank	DHD340A Or Cop44
Hole Range	108-130mm
Connection Thread	API 2 3/8" Reg
Package Dimension	1020X130X160 (mm)
Percussion Rate	1500(17 Bar)
Operating Pressure	7-24 Bar
RPM Recommended	30-55
Air Consumption	200-300 Psi
	500-700 CFM



DTH 5 Inch

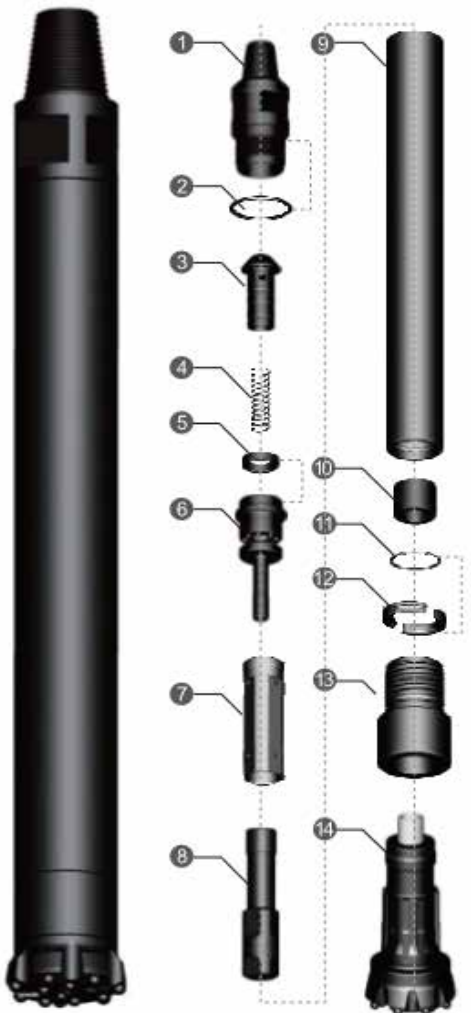

Item	Description	Part Number
1	Top Sub 3 1/2"	HD520010001
2	"O" Ring	HD520010002
3	Check Valve	HD520010003
4	Spring	HD520010004
5	Buffer Ring	HD520010005
6	Air Distributor	HD520010006
7	Internal Cylinder	HD520010007
8	Piston	HD520010008
9	External Cylinder	HD520010009
10	Guide Sleeve	HD520010010
11	"O" Ring of Stop Ring	HD520010011
12	Bit Retaining Ring	HD520010012
13	Driver Sub	HD520010013
14	Drill Bit	See Page

Complete Hammer Product Code	Description	Part Number
62-5-QL50-30-G	HRD5 Hammer with QL50	HD5200100A

Technical Data

Lenth (W/O Bit)	935mm
Weight(W/O Bit)	65Kg
Out Diameter	126mm
Shank	QL50
Hole Range	140-152mm
Connection Thread	API 3 1/2" Reg
Package Dimension	1100X155X180 (mm)
Percussion Rate	1500(17 Bar)
Operating Pressure	7-24 Bar
RPM Recommended	30-45
Air Consumption	250-350 Psi
	500-800 CFM



DTH 6 Inch

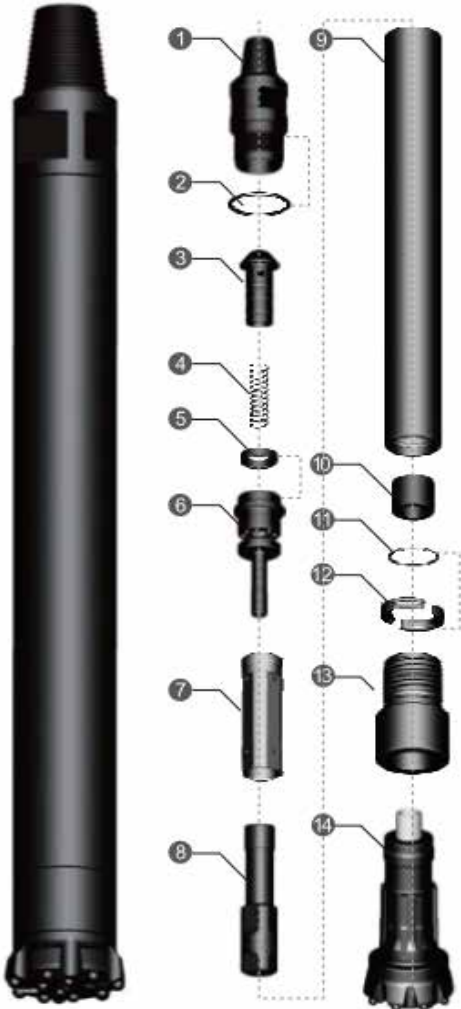

Item	Description	Part Number
1	Top Sub 3 1/2"	HD600010001
2	"O" Ring	HD600010003
3	Check Valve	HD600010004
4	Spring	HD600010005
5	Buffer Ring	HD600010006
6	Air Distributor	HD600010007
7	Internal Cylinder	HD600010008
8	Piston	HD600010009
9	External Cylinder	HD600010010
10	Guide Sleeve	HD600010011
11	"O" Ring of Stop Ring	HD600010012
12	Bit Retaining Ring	HD600010013
13	Driver Sub	HD600010014
14	Drill Bit	See Page

Complete Hammer Product Code	Description	Part Number
62-6-QL60-30-G	HRD6 Hammer with QL60	HD6000100A

Technical Data

Lenth (W/O Bit)	1183mm
Weight(W/O Bit)	92Kg
Out Diameter	148mm
Shank	QL60
Hole Range	165-203mm
Connection Thread	API 3 1/2" Reg
Package Diamension	1260X180X200 (mm)
Percussion Rate	1500(17 Bar)
Operating Pressure	7-24 Bar
RPM Recommended	20-40
Air Consumption	300-350 Psi
	600-900 CFM



DTH 8 Inch

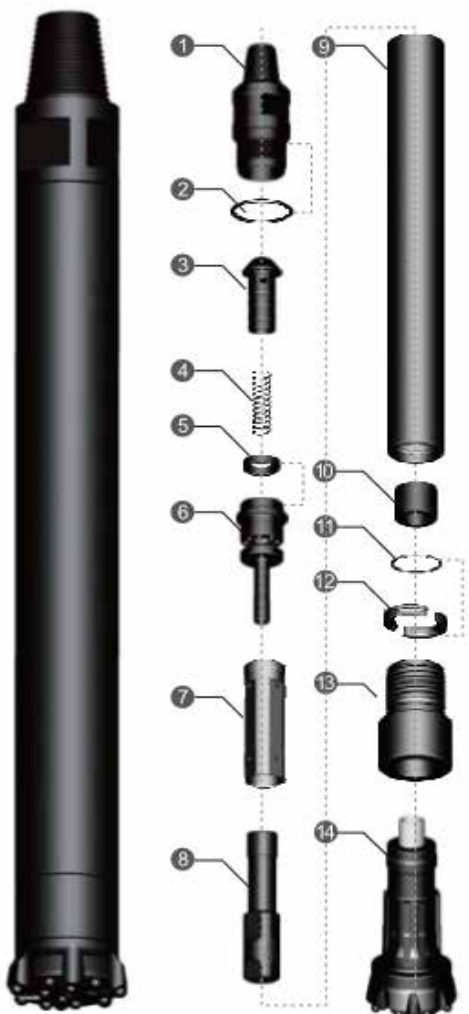

Item	Description	Part Number
1	Top Sub 4 1/2"	HD800010001
2	"O" Ring	HD800010002
3	Check Valve	HD800010003
4	Spring	HD800010004
5	Buffer Ring	HD800010005
6	Air Distributor	HD800010006
7	Internal Cylinder	HD800010007
8	Piston	HD800010008
9	External Cylinder	HD800010009
10	Guide Sleeve	HD800010010
11	"O" Ring of Stop Ring	HD800010011
12	Bit Retaining Ring	HD800010012
13	Driver Sub	HD800010013
14	Drill Bit	See Page

Complete Hammer Product Code	Description	Part Number
62-8-QL80-40-G	HRD8 Hammer with Q860	HD80001000A

Technical Data

Lenth (W/O Bit)	1340mm
Weight(W/O Bit)	172Kg
Out Diameter	185mm
Shank	QL80
Hole Range	203-254mm
Connection Thread	API 4 1/2" Reg
Package Dimension	1440X230X270 (mm)
Percussion Rate	1500(17 Bar)
Operating Pressure	7-24 Bar
RPM Recommended	20-45
Air Consumption	300-380 Psi
	950-1200 CFM

Integral and Taper Rod

TH Thread Products

Shank Adapter

DTH Hammer

DTH Bit

DTH Pipe

Rotary Tools

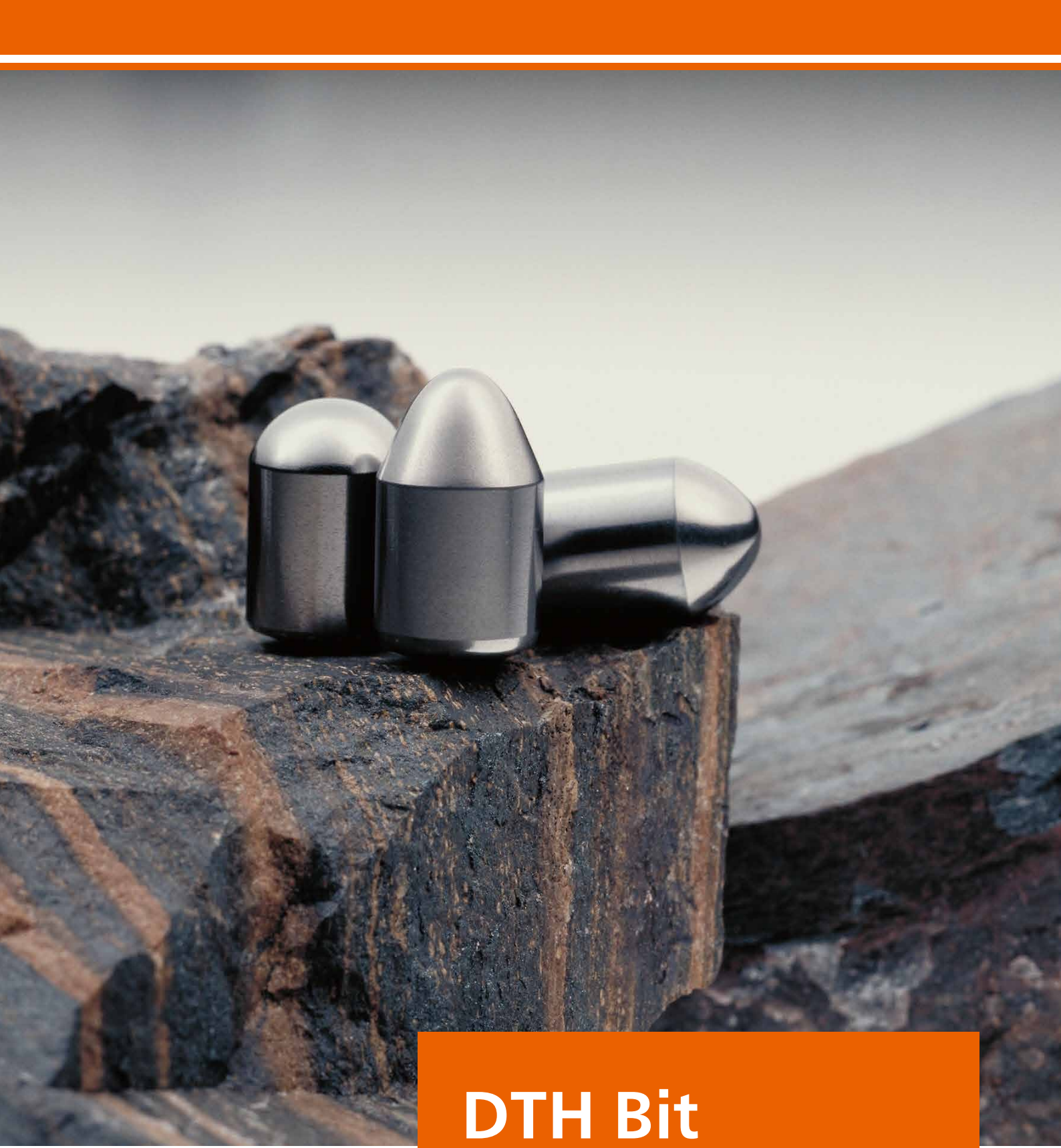





DTH Bit

DTH Bit Design

DTH BIT

Face Specifications

Face	Button	Applications
<p>Concave face</p> 	 <p>Ballistic</p>  <p>Semi-Ballistic</p>	<ul style="list-style-type: none"> ● Soft to medium rock ● Non Abrasive ● Soft to medium rock ● Abrasive
<p>Flat face</p> 	 <p>Spherical</p>	<ul style="list-style-type: none"> ● Hard rock ● Abrasive



DTH BIT DESIGN

Dia		Product No.	Product Code	Buttons		Flushing Holes	Weight (kg)	Shank
mm	In			Gauge No. X Size	Center No. X Size			

DHD340A Concave / Ballistic

108	4 1/4	HD41101001	613-108D340-814/712-22-41	8X14	7X12	2	7.80
115	4 1/2	HD41101002	613-115D340-814/712-22-41	8X14	7X12	2	9.00
130	5 1/8	HD41101003	613-130D340-816/714-22-41	8X16	7X14	2	11.50

DHD340A Flat Face / Spherical

108	4 1/4	HD41101004	611-108D340-814/612-22-41	8X14	6X12	2	8.00
115	4 1/2	HD41101005	611-115D340-814/712-22-41	8X14	6X12	2	9.00
115	4 1/2	HD41101006	611-115D340-818/714-22-41	7X18	6X14	2	9.00
130	5 1/8	HD41101007	611-115D340-816/814-22-41	8X16	8X14	2	11.50



QL50 Concave / Ballistic

140	5 1/2	HD52101001	613-140QL50-816/814-22-41	8X16	8X14	2	14.00
152	6	HD52101002	613-152QL50-816/014-22-41	8X16	10X14	2	16.00

QL50 Flat Face / Spherical

140	5 1/2	HD52101003	611-140QL50-816/814-22-41	8X16	8X14	2	14.00
152	6	HD52101004	611-152QL50-816/014-22-41	8X16	10X14	2	16.00



QL60 Concave / Spherical

165	6 1/2	HD63101001	613-165QL60-918/816-22-41	9X18	8X16	3	25.50
178	7	HD63101002	613-178QL60-918/016-22-41	9X18	10X16	3	29.00

QL60 Flat Face / Spherical

165	6 1/2	HD63101003	611-165QL60-918/818-22-41	9X18	8X18	3	26.00
178	7	HD63101004	611-178QL60-918/018-22-41	9X18	10X18	3	30.00
203	8	HD63101005	611-203QL60-018/016-22-41	10X18	14X16	3	33.00



QL80 Concave / Spherical

203	8	HD84101001	611-203QL80-018/018-22-41	10X18	14X18	3	50.00
229	9	HD84101002	611-229QL80-018/016-22-41	12X18	16X16	3	55.00
254	10	HD84101003	611-254QL80-018/018-22-41	12X18	18X18	3	64.00





DTH Pipe

DTH PIPE

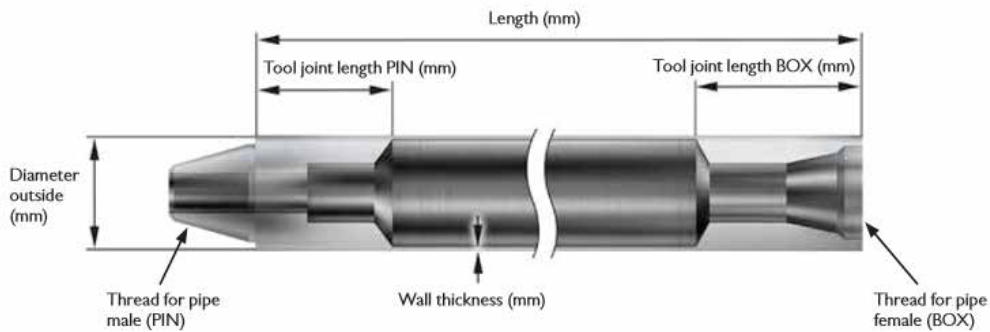

OD	Wall Thickness	Length (S/S,mm)	Pin Thread	Box Thread	Tool Joint Pin Box (mm)	Tool Joint length Box (mm)	Wrench Flat	Weight (Kg)	Part Number
76	4.0	3000	API 2 3/8" Reg	API 2 3/8" Reg	110	165	Y	25	HDP0001001
76	6.3	3000	API 2 3/8" Reg	API 2 3/8" Reg	110	165	Y	34	HDP0001002
89	4.0	3000	API 2 3/8" Reg	API 2 3/8" Reg	110	160	Y	30	HDP0001003
89	6.3	3000	API 2 3/8" Reg	API 2 3/8" Reg	110	160	Y	44	HDP0001004
89	8.8	5000	API 2 3/8" Reg	API 2 3/8" Reg	350	350	N	92	HDP0001005
89	8.8	6000	API 2 3/8" Reg	API 2 3/8" Reg	350	350	N	115	HDP0001006
102	6.3	4000	API 2 7/8" Reg	API 2 7/8" Reg	270	270	N	75	HDP0001007
102	6.3	5000	API 2 7/8" Reg	API 2 7/8" Reg	270	270	N	90	HDP0001008
102	8.8	6000	API 2 7/8" Reg	API 2 7/8" Reg	350	350	N	115	HDP0001009
114	6.3	5000	API 3 1/2" Reg	API 3 1/2" Reg	350	350	N	120	HDP0001010
114	6.3	5000	API 3 1/2" Reg	API 3 1/2" Reg	270	270	N	125	HDP0001011
114	6.3	5000	API 3 1/2" Reg	API 3 1/2" Reg	270	270	N	160	HDP0001012

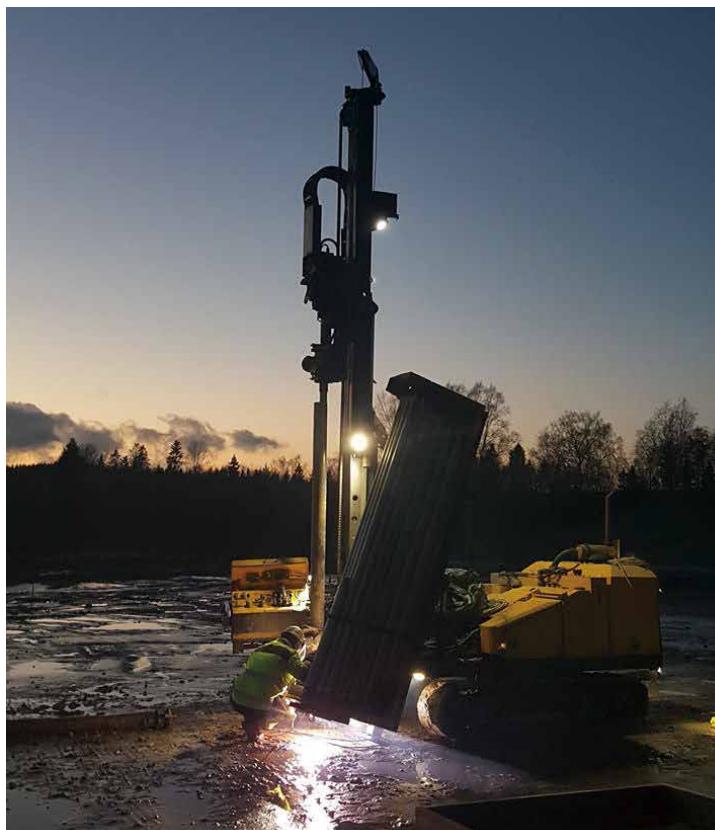

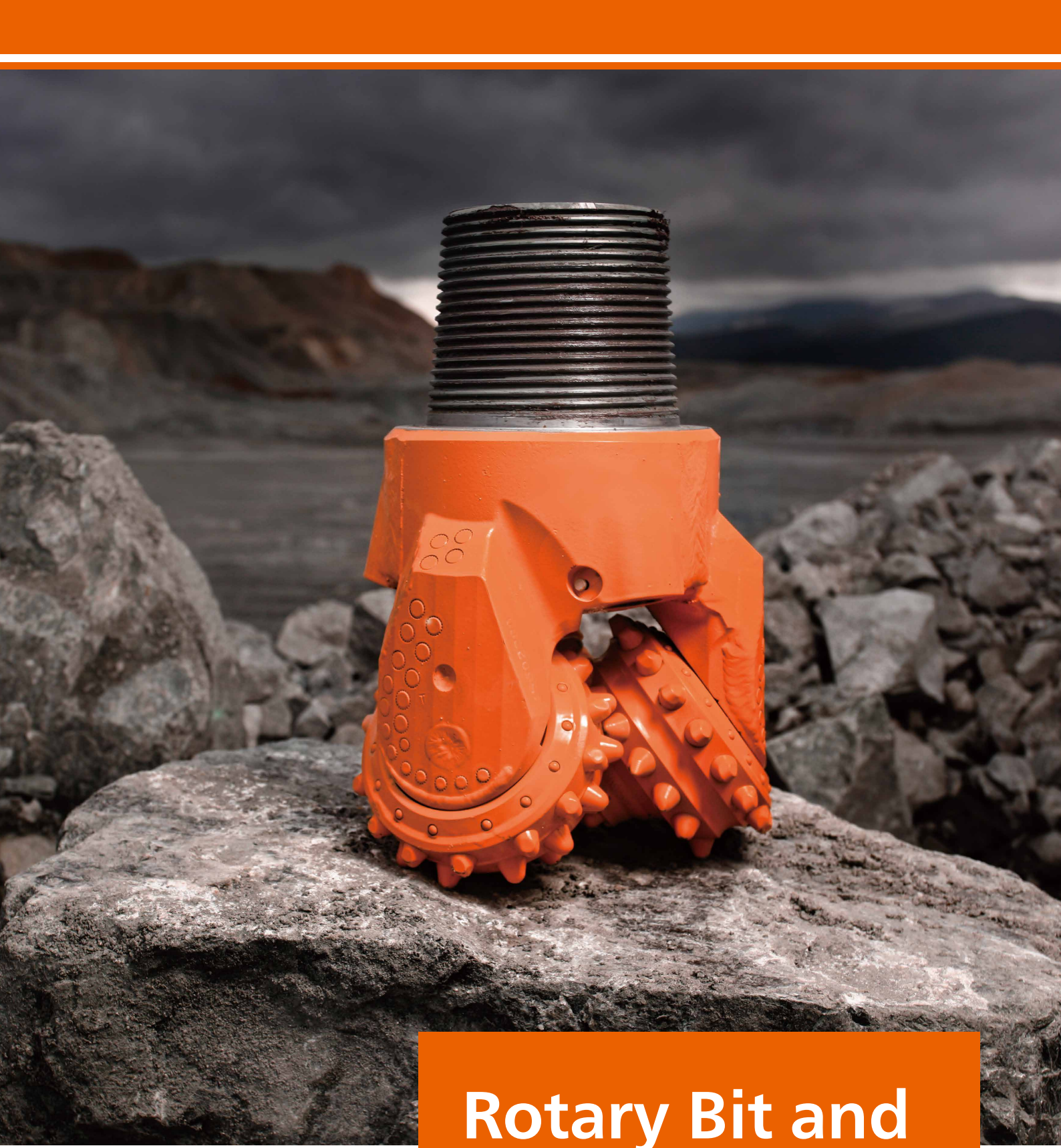

Rotary Bit and Drill String

Rotary Bit

HardROC Tricone Bit was manufacture by imported bearing system which result in very good air bearing bits in the surface mining industry. The good bearing system and highest quality process shown maximize life and operational penetration rates in challenging environments.

Rotary Bit

Series	Application	Operating Parameters	
		Rotating Speed (RPM)	Weight on Bit - WOB (lb/in)
30	Very Soft	70-140	1000 to 4000
40	Soft	70-140	1000 to 4000
50	Soft to Medium	50-140	2000 to 5000
60	Medium to Hard	50-110	3000 to 6000
70	Hard	50-90	3500 to 7500
80	Extremely Hard	40-80	5000 to 8000

Bit Size		Pin Size
in	mm	
5 5/8	143	API 3 1/2 Reg
6 3/4	171	API 4 1/2 Reg
7 7/8	200	
8 1/2	216	
9	229	
9 7/8	251	API 6 5/8 Reg
10 5/8	270	
11	279	
12 1/4	311	
13 3/4	350	API 7 5/8 Reg
16	406	

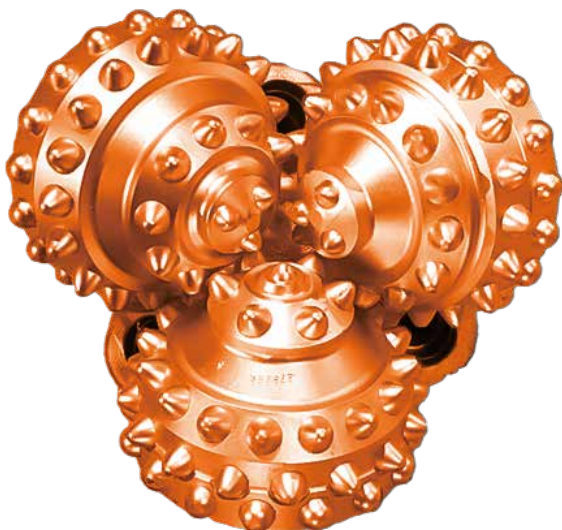

Rotary Drill String

HardROC Rotary drill string includes pipes, Deck Bushing and Adapters. The Drill String is using the highest quality tool joints with optional tubes to meet different requirement.

OUT DIAMETER		WALL THICKNESS		TUBE WEIGHT		RECOMMENDED CONNECTIONS	MATERIAL GRADE
mm	in	mm	in	mm	in		
127	5	19.05	3 / 4	51	34	3 1/2 " BECO	A106B/4145H/4330
140	5 1/2	19.05	3 / 4	57	38	3 1/2 " BECO	A106B/4145H/4330
152	6	19.05	3 / 4	63	42	4 " BECO	A106B/4145H/4330
152	6	25.4	1	79	53	4 " BECO	A106B/4145H/4330
159	6 1/4	19.05	3 / 4	65	44	4 " BECO	A106B/4145H/4330
165	6 1/2	19.05	3 / 4	68	46	4 1/2" BECO	A106B/4145H/4330
165	6 1/2	25.4	1	88	59	4 1/2" BECO	A106B/4145H/4330
178	7	19.05	3 / 4	74	50	4 1/2" BECO	A106B/4145H/4330
178	7	25.4	1	95	64	4 1/2" BECO	A106B/4145H/4330
194	7 5/8	22.2	7 / 8	94	63	5 1/4 BECO	A106B/4145H/4330
194	7 5/8	25.4	1	106	71	5 1/4 BECO	A106B/4145H/4330
219	8 5/8	25.4	1	122	82	6" BECO	A106B/4145H/4330
219	8 5/8	38.1	1 1/2	170	114	6" BECO	A106B/4145H/4330
235	9 1/4	25.4	1	131	88	6" BECO	A106B/4145H/4330
273	10 3/4	25.4	1	155	104	8" BECO	A106B/4145H/4330
273	10 3/4	38.1	1 1/2	220	148	8" BECO	A106B/4145H/4330



Integral and Taper Rod

TH Thread Products

Shank Adapter

DTH Hammer

DTH Bit

DTH Pipe

Rotary Tools



To be first choice by professional
and International way of work



HardROC International Trading (Shanghai) Co., Ltd.

Address: Room 368, No. 211, Futebeilu, China (Shanghai)
PilotFreeTradeZone, Shanghai

Telephone: 021-65667599